

# The Dijkstra Algorithm

Antonio Carzaniga

Faculty of Informatics  
Università della Svizzera italiana

May 14, 2024

- Very similar to Prim's algorithm

- Very similar to Prim's algorithm
- Variables storing values known at each iteration

- Very similar to Prim's algorithm
- Variables storing values known at each iteration
  - ▶  $D[v]$ , cost of the least-cost path from  $u$  to  $v$

- Very similar to Prim's algorithm
- Variables storing values known at each iteration
  - ▶  $D[v]$ , cost of the least-cost path from  $u$  to  $v$
  - ▶  $P[v]$ , node preceding  $v$  (neighbor of  $v$ ) on the least-cost path from  $u$  to  $v$

- Very similar to Prim's algorithm
- Variables storing values known at each iteration
  - ▶  $D[v]$ , cost of the least-cost path from  $u$  to  $v$
  - ▶  $P[v]$ , node preceding  $v$  (neighbor of  $v$ ) on the least-cost path from  $u$  to  $v$
  - ▶  $N$ , nodes of  $G$  whose least-cost path from  $u$  is definitely known

**DIJKSTRA**( $G, u, w$ )

```
1   $N = \emptyset$ 
2  for each vertex  $v \in V(G)$ 
3       $D[v] = \infty$ 
4       $P[v] = \text{NIL}$ 
5   $D[u] = 0$ 
6  while  $N \neq V(G)$ 
7      find  $u \notin N$  such that  $D[u]$  is minimal
8       $N = N \cup \{u\}$ 
9      for all  $v \in \text{Adj}(u) \setminus N$ 
10         if  $D[u] + w(u, v) < D[v]$ 
11              $D[v] = D[u] + w(u, v)$ 
12              $P[v] = u$ 
```

# Example

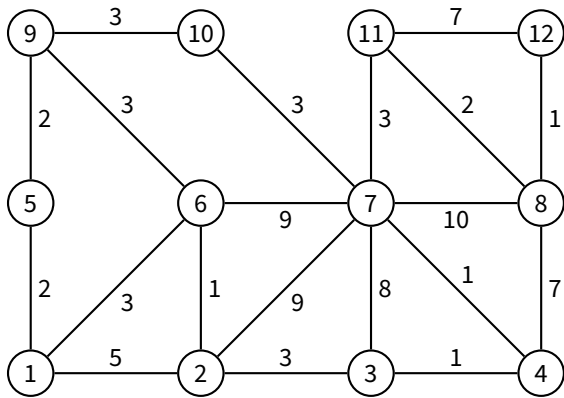

# Example

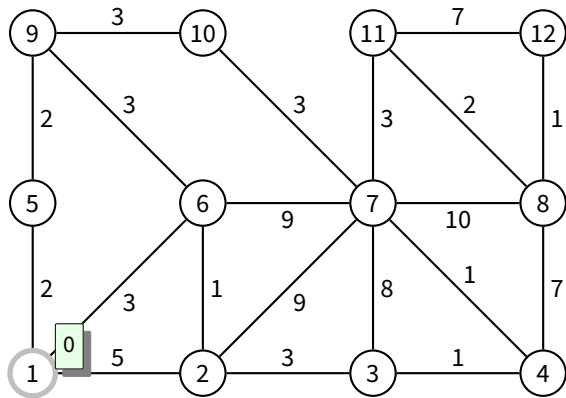

# Example

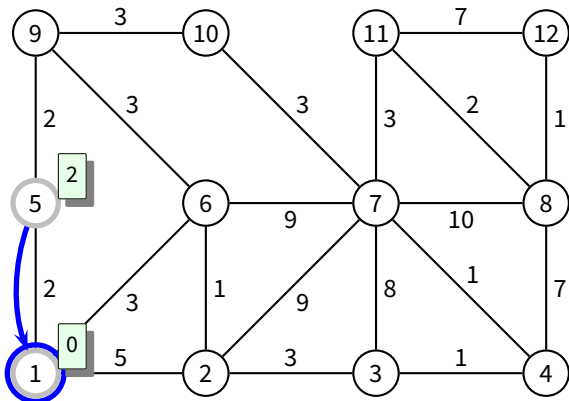

# Example

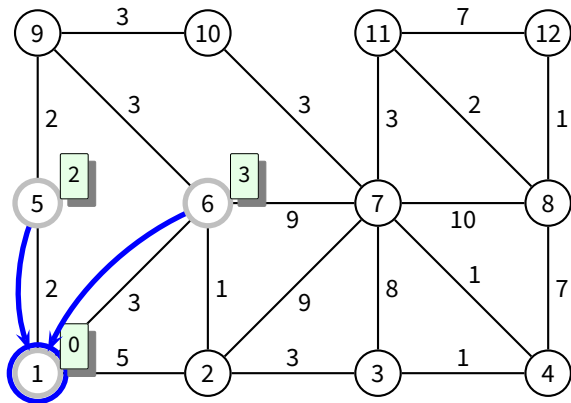

# Example

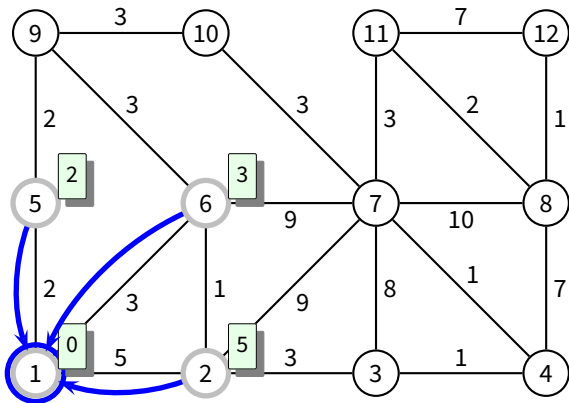

# Example

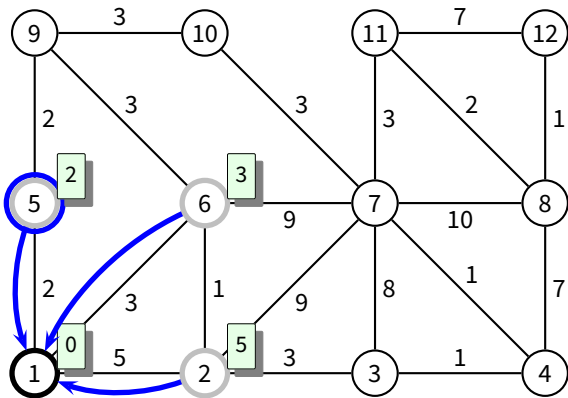

# Example

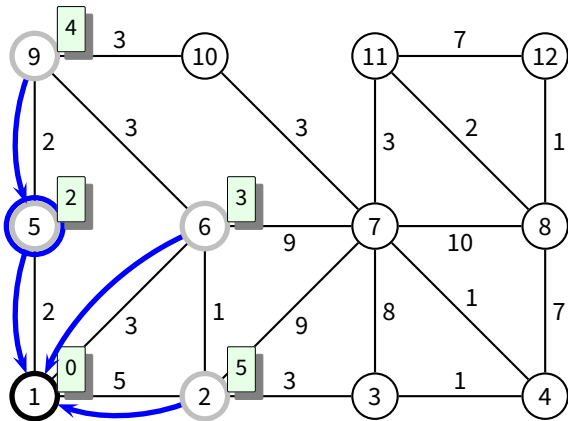

# Example

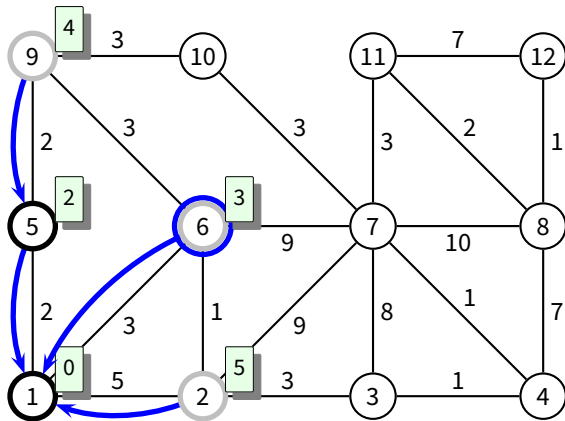

# Example

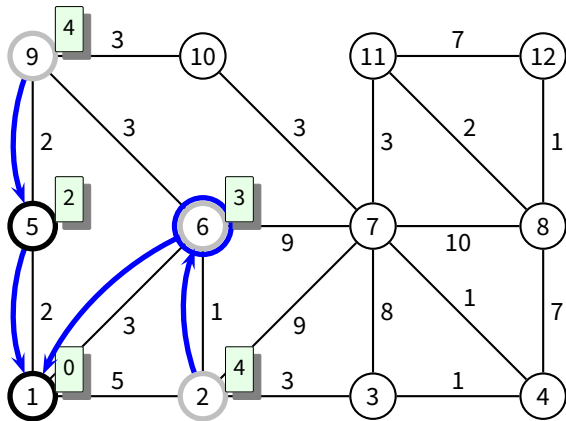

# Example

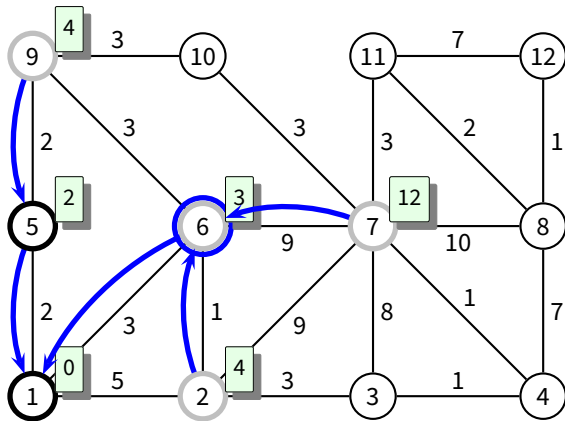

# Example

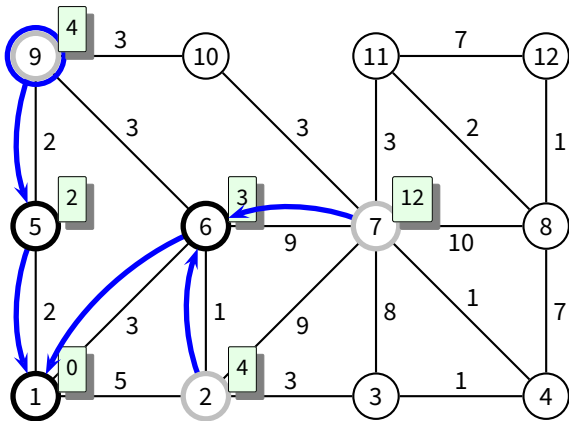

# Example

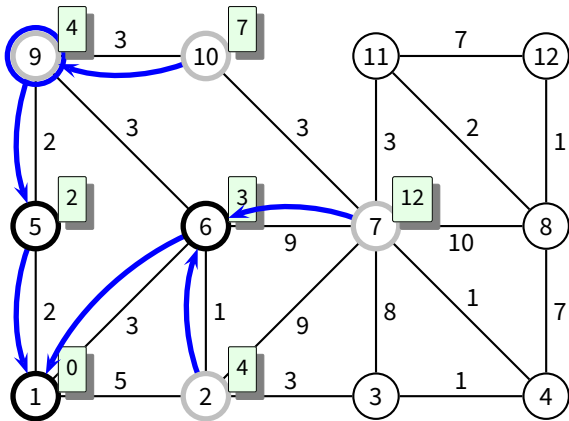

# Example

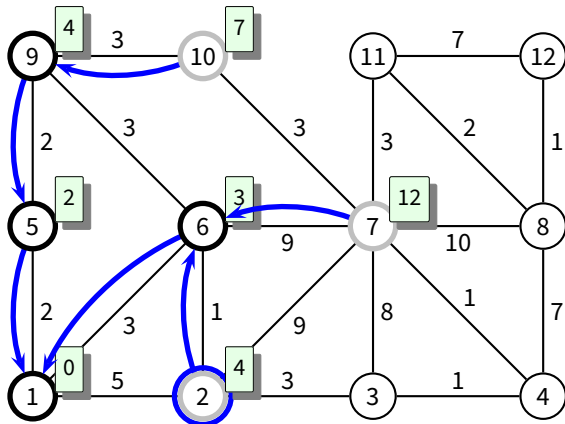

# Example

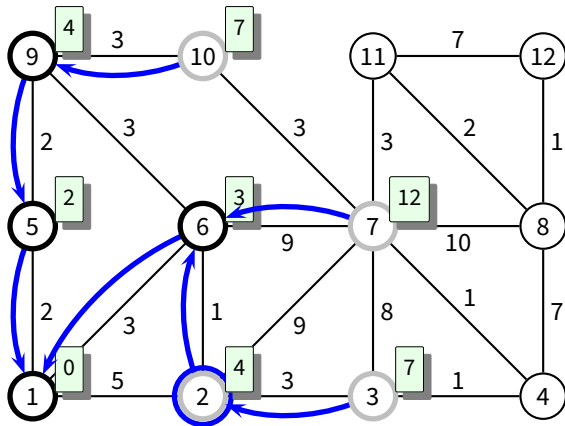

# Example

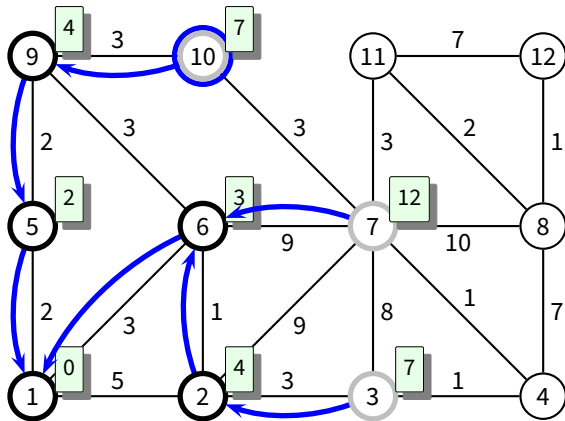

# Example

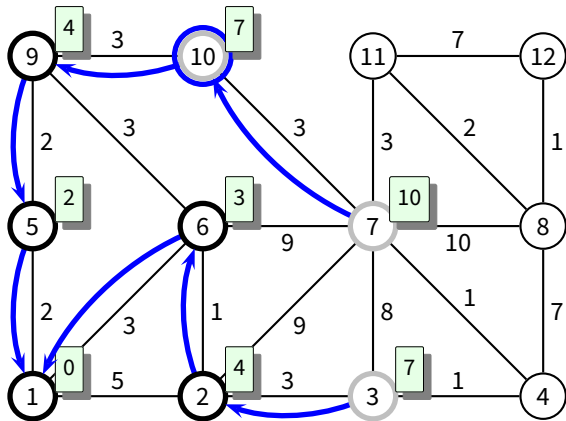

# Example

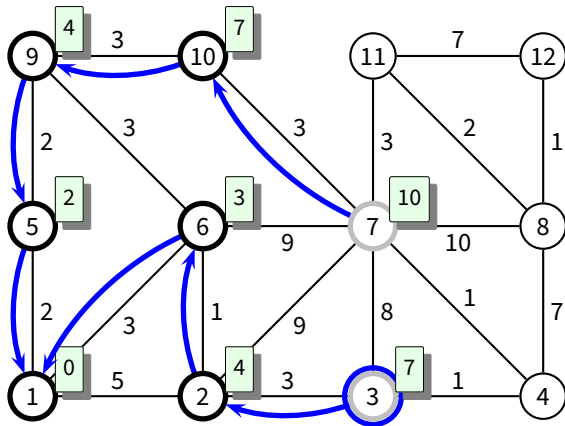

# Example

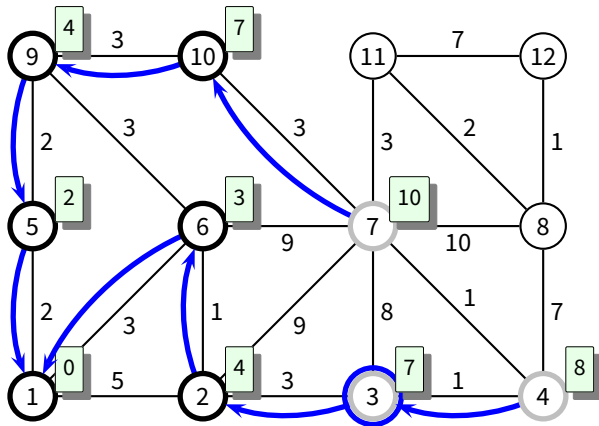

# Example

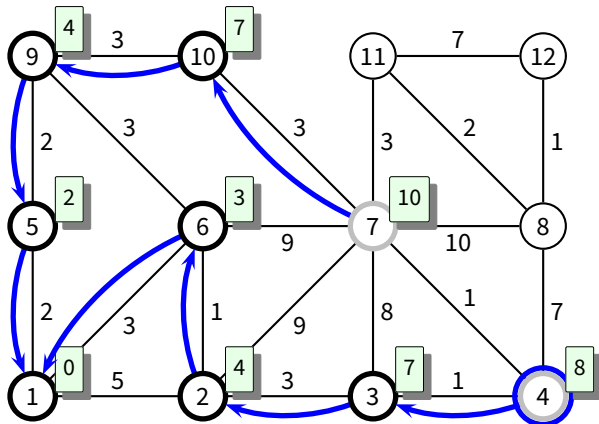

# Example

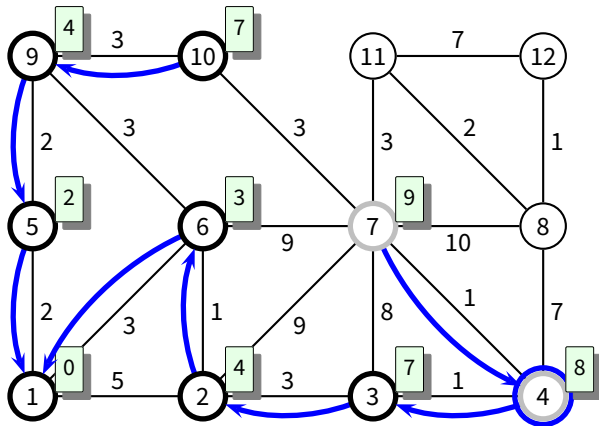

# Example

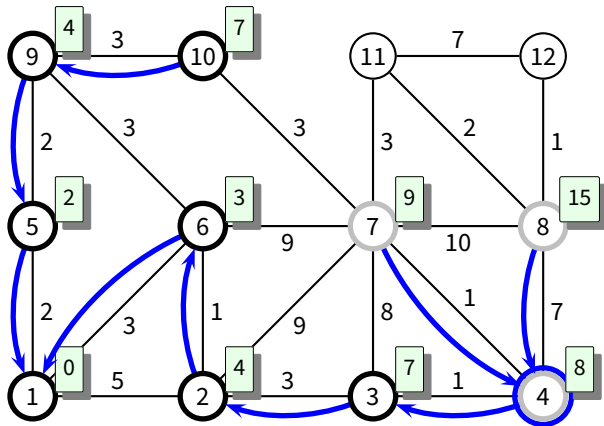

# Example

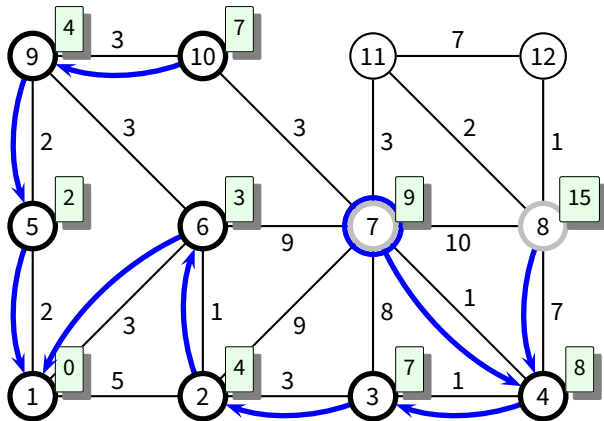

# Example

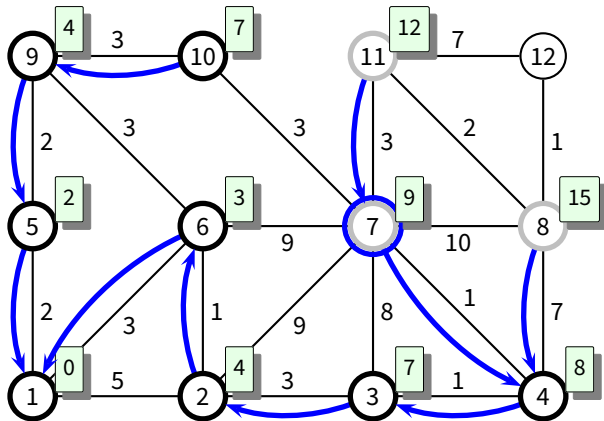

# Example

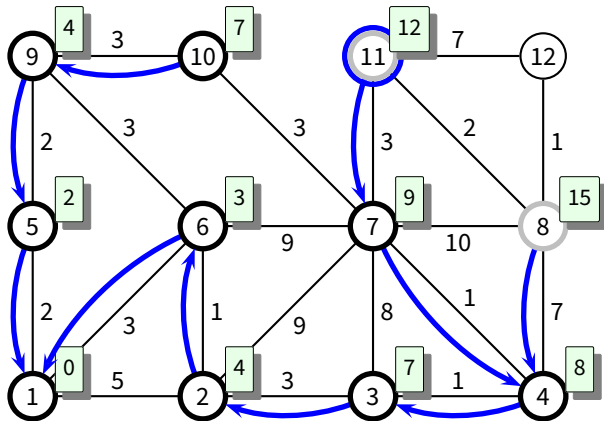

# Example

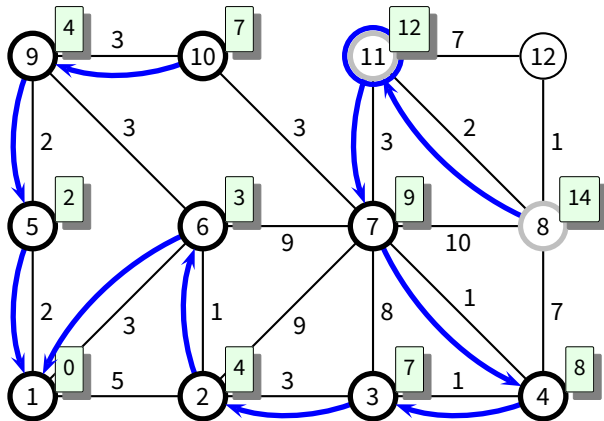

# Example

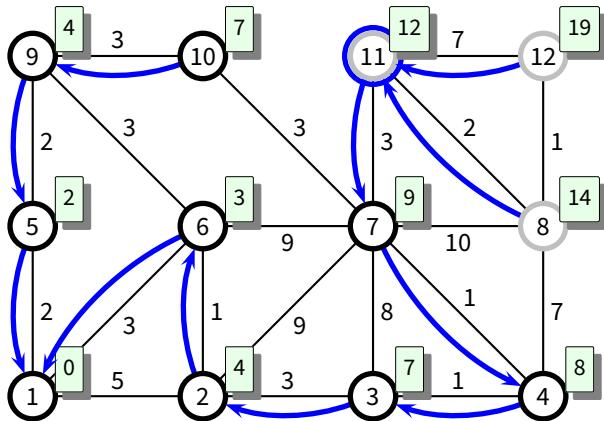



# Example

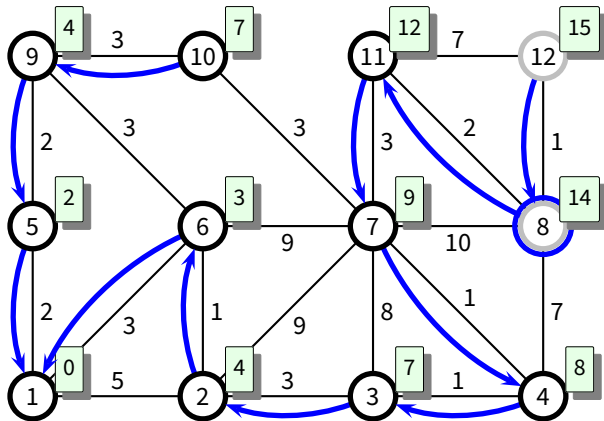

# Example

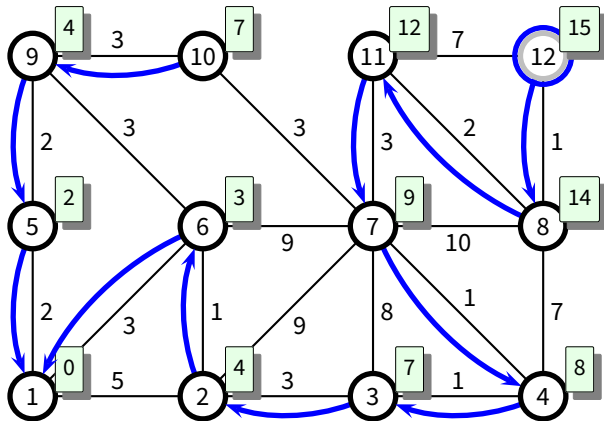

# Example

