

Computer Networking

Exercises

Antonio Carzaniga
Faculty of Informatics
USI
(Università della Svizzera italiana)

Edition 2.0
September 2016

- ▶ **Exercise 1.** Consider a DNS query of type *A* within a DNS system containing *IN* class information. Using boxes to represent servers and lines with labels to represent packets, diagram an *iterative request* for “www.ban.mcyds.net”. The answer must be authoritative. Label any DNS servers you need to contact using a descriptive label. Label every packet with the essential information. For example, a box may be labeled “authority for .com,” while a packet might be labeled “answer, www.ban.mcyds.net, 192.168.23.45” (10’)
- Consider the same DNS request specified above. Now create a new diagram showing a *recursive request*. Once again, the answer must be authoritative. (10’)
- ▶ **Exercise 2.** Given the utility functions listed below, write the pseudo-code to perform an *iterative* DNS lookup.

```

dns_query_pkt make_dns_packet(type, class, flags)
Creates a new DNS query packet. Flags can be combined via the ‘|’ operator. So
for a query that is both authoritative and recursive, one would write: (DNS_AUTH |
DNS_RECURSE). Only the DNS_AUTH and DNS_RECURSE flags are valid. Type can be A,
MX, NS, or any other valid DNS type.

value get_dns_answer(dns_answer_packet, n)
Return the value in the nth answer of a dns_answer_pkt packet. For example, in re-
ply to a MX lookup for inf.unisi.ch, get_dns_answer(pkt, 1) would return the SMTP
mail server for the inf.unisi.ch domain. In reply to a NS query it would return the
authoritative name server.

dns_answer_packet send_and_wait(dns_query_packet, server)
Send the given dns_query_packet and wait for a replay from the given DNS server.
Returns a dns_answer_packet.

```

By “pseudo-code” here we mean a simplification of an actual program that shows only the essential operations. The syntax we expect is that of Java, or C if you prefer. Do not worry about the details of the program. For example, if you need to output something, just write something like “print(...).” Insert comments in your code to describe your ideas. What counts here is that the procedure you implement be clear at a high-level. (Hint: the operation corresponds to the execution of *dig* with the *+trace* option.) (20’)

```

// Implement your code here.
void ns_trace(server_name) {
Given the same functions listed on the previous page, write the pseudo code to perform a recursive
DNS lookup. (10’)

// Implement your code here.
void ns_recurse_lookup(server_name) {

```

- ▶ **Exercise 3.** Design an extension to HTTP to support *ratings* for documents. Every document may be rated by users on a scale of 1-100. An HTTP server computes and stores the average ratings of each document. An HTTP server should also return the rating of a document when that is requested by a client. Which HTTP *method* would you use to send a new rating to a server? Give an example of an HTTP request containing a rating. (5’)
- How would you modify a *GET* request in order to include a rating query from a client? Show a corresponding HTTP request as an example. What if the client is interested only in the ratings? Show another HTTP request that returns the rating without returning the content. (5’)
- ▶ **Exercise 4.** The following is an SMTP conversation containing only the responses from the server. Fill in the blanks with the messages sent by the client. (15’)

Server: 220 mx.duder.org ESMTP Sendmail 8.12.10; Mon, 9 May 2005 12:26:27 -0600 (PST)
Client:

Server: 250 mx.duder.org. Hello mail.bowlingalley.net [171.33.22.6], pleased to meet you

Client:

Server: 250 2.1.0 donnie@bowlingalley.net... Sender ok

Client:

Server: 550 5.1.1 dude@mx.duder.org... User unknown

Client:

Server: 250 2.1.5 thedude@mx.duder.org... Recipient ok

Client:

Server: 354 Enter mail, end with "." on a line by itself

Client:

Server: 250 2.0.0 j49IQRp8013851 Message accepted for delivery

Client:

Server: 221 2.0.0 mx5.Colorado.EDU closing connection

- **Exercise 5.** Consider the following SMTP message. Separate the headers added by transport agents from those added by the user agent or delivery agents. Do that by drawing a line between the two sets of headers. Write a label above and below the line marking which set of headers are from the transport-agent and which set are from other agents. You may need to draw more than one line. (5')

```
Delivered-To: hallc@lu.unisi.ch
Received: from spamfilter.usilu.net by campus9.usilu.net
        with Microsoft SMTPSVC; Fri, 11 Mar 2005 23:07:56 +0100
Received: from localhost (spamfilter.usilu.net) by
        spamfilter.usilu.net (Postfix) with ESMTP id C2AC07C17D for
        <hallc@lu.unisi.ch>; Fri, 11 Mar 2005 23:07:55 +0100 (CET)
Received: from spamfilter.usilu.net by localhost
        (spamfilter.usilu.net) (amavisd-new, port 10024) with ESMTP id
        02298-08 for <hallc@lu.unisi.ch>;
        Fri, 11 Mar 2005 23:07:53 +0100 (CET)
Received: from mail-fs.sunrise.ch (mta-fs-be-01.sunrise.ch)
        by spamfilter.usilu.net (Postfix) with ESMTP id
        68A397C017 for <hallc@lu.unisi.ch>;
        Fri, 11 Mar 2005 23:07:52 +0100 (CET)
Received: from [187.22.132.87] by mail-fs.sunrise.ch
        id 422D8BF5001729DB for hallc@lu.unisi.ch; Fri, 11 Mar 2005
        23:07:52 +0100
Mime-Version: 1.0 (Apple Message framework v619.2)
Content-Transfer-Encoding: 7bit
Message-Id: <7d7e7812ec273c6e2e26842e834324ef@lu.unisi.ch>
Content-Type: text/plain; charset=US-ASCII; format=flowed
To: Cyrus Hall <hallc@lu.unisi.ch>
From: The Dude <thedude@duder.org>
Subject: my rug is gone
Date: Fri, 11 Mar 2005 23:07:41 +0100
X-Mailer: Apple Mail (2.619.2)
X-Virus-Scanned: by amavisd-new at usilu.net
Return-Path: thedude@duder.org
X-OriginalArrivalTime: 11 Mar 2005 22:07:56.0089 (UTC)
Could the message of the previous page be valid? Justify your answer. (5')
```

- **Exercise 6.** Below is an HTTP response from the server www.unisi.ch.

```
HTTP/1.0 302 Found
Location: http://www.unisi.ch/
Content-Type: text/html
Server: Apache/1.3.29 (Win32)
Last-Modified: Thu, 03 May 2001 16:00:38 GMT
Content-Length: 1494
Date: Mon, 09 May 2005 20:37:25 GMT
Connection: close
Expires: Mon, 09 May 2005 20:45:02 GMT
```

Give a HTTP request that could generate such a response. (5')

Below is an HTTP request.

```
PUT /files/uploads/private/tbl.avi HTTP/1.1
Host: www.personalpage.net
Content-Type: video/x-msvideo
Content-Length: 1822990
```

...a bunch of binary data goes here...

Enumerate at least four responses that an HTTP server could give. Only show the response line of each response. (10')

- **Exercise 7.** An HTTP document is made of the following three objects: x.html (1Kb), x.jpg (50Kb), and x.png (100Kb). Assuming that the underlying transport layer has a constant throughput $T = 100\text{KB/s}$ and that the latency between the client and the origin server is $L = 500\text{ms}$, compute the total time $\Delta_{1.1}$ that it would take an HTTP/1.1 browser using pipelining to retrieve the entire document. Assume the server is able and willing to serve (HTTP/1.1) pipelined requests. Also compute the total download time $\Delta_{1.0}$ in the case of an HTTP/1.0 client that does not use pipelining. For the purpose of your calculations, you may assume that the size of HTTP headers (both requests and responses) are negligible. (10')

Now assume the client is connected to the origin server through a caching proxy. Under the same assumption of a constant throughput at the transport level, given that the latency with the proxy is $L_p = 100\text{ms}$, that the throughput with the proxy is $T_p = 1000\text{KB/s}$, that the latency between the proxy and the origin server is $L_{p-o} = 500\text{ms}$, and that the throughput there is $T_{p-o} = 100\text{KB/s}$, compute the total download time for an HTTP/1.1 client using pipelining, assuming that the two images (x.jpg and x.png) are cached, while x.html is not. (10')

- **Exercise 8.** Consider a reliable transport layer implemented through a Go-Back-N protocol, with maximum segment size $MSS = 1\text{KB}$, and with a fixed window size $W = 10$. Suppose the sender transmits at the maximum speed allowed by the protocol and that the network has plenty of bandwidth and no congestion, suppose also that the underlying network loses, on average, one segment out of 1000, and suppose that each segment, whether a data segment or an acknowledgment, has a 2-byte header, with acknowledgment segments having no content.

On average, what is the total number of bytes sent into the network by both the sender and the receiver to transfer a 10MB file? Briefly justify your answer. (Assume $1\text{MB} = 1000\text{KB}$ and $1\text{KB} = 1000\text{B}$.) (15')

- **Exercise 9.** Briefly describe the algorithm used by TCP to control the size of its congestion window. Complete your description with a diagram showing how the window size might vary over time, in response to every protocol event. (10')

- **Exercise 10.** Briefly explain the functionality of the SYN flag in the TCP header. (5')

- **Exercise 11.** A TCP segment with sequence number 1234 carries the following HTTP request:

```
HTTP/1.0 404 Not Found
Content-Type: text/html
Content-Length: 200
```

```
<html><body>Not Found!
...more html text here...
</body></html>
```

What is the sequence number of the next segment? Briefly justify your answer. (Remember that all HTTP header lines end with a CRLF sequence.) (10')

- **Exercise 12.** Outline the UDP header format. What kind of transport-level features does UDP provide? Say whether each feature relates to any header field, and if so, describe how. (10')

- **Exercise 13.** Describe the high-level architecture of a router. Explain where a router queues packets. For each packet queue, explain why that queue is necessary and what circumstances may cause that queue to fill up. (10')

- **Exercise 14.** Consider the forwarding function of a router within (1) an IPv4 network, (2) a generic packet-switched network, and (3) a generic virtual-circuit network. For each case, write the "signature" of the forwarding function in terms of its domain (input set) and range (output set) for a

router (e.g., the signature of the logarithm function is $\text{LOG} : R \rightarrow R^+$, where R^+ represents positive real numbers and R represents all real numbers). Comparing (2) and (3), tell which function would be simpler to compute. Justify your answer. (5')

► **Exercise 15.** A router receives a non-fragmented 1400-bytes IPv4 packet from interface 1, and decides to forward it to interface 2, which has an MTU of 512 bytes. Explain in detail how the router compiles the output packet(s). Write your explanation in the form of pseudo-code. Refer to the input packet as X and to the output packet(s) as Y_1, Y_2 , etc. Refer to header fields using a Java-like dot notation. E.g., refer to the source address of the input packet as $X.\text{source}$ and to the first 100 bytes of payload as $Y.\text{data}[0 \dots 99]$. Assume the input packet has no options. (Hint: the first step could be something like this: " $Y_1.\text{source} \leftarrow X.\text{source}$ ") (15')

► **Exercise 16.** Express the following address ranges using the subnet prefix notation. If a range can not be represented with the prefix notation, write "N.A."

<i>range</i>	<i>subnet prefix-address/prefix-length</i>
67.56.34.64-67.56.34.79	
121.232.111.128-121.232.111.255	
121.34.56.64-121.34.56.128	
128.131.9.0-128.131.9.192	
108.47.200.192-108.47.200.223	
93.20.10.0-93.20.11.0	
128.242.138.0-128.242.139.127	
200.220.76.0-200.220.79.255	
200.220.0.0-200.223.255.255	

For each valid prefix you wrote above, write the corresponding address/mask expression (15')

► **Exercise 17.** Given the following set of prefixes, write an equivalent minimal set of prefixes by simplifying the list (i.e., by applying "supernetting").

128.138.242.0/24	
128.138.243.0/24	
128.138.0.0/16	
108.47.128.0/22	
108.47.136.0/21	
108.47.132.0/22	
128.138.128.0/22	
128.138.136.0/21	
138.138.132.0/22	

(10')

► **Exercise 18.** Outline the structure of an entire IPv6 packet containing a UDP packet containing a simple HTTP 1.0 request. Referring to each field using a symbolic identifier, fill in as many header fields and payload data as possible. Use sensible data. For each field, explain very briefly your choice of value. For example, you might write " $IP.\text{source} = 123456789$: value chosen at random." Make sure to mention any relation between fields. (10')

► **Exercise 19.** Compare IPv4 with IPv6. List the major differences between the two protocols. Briefly explain the design rationale for each difference. (10')

► **Exercise 20.** Consider a router in an IPv4 network using longest-prefix matching. The router has the following forwarding table:

entry	destination	interface
1	98.7.1.0/16	1
2	211.57.20.0/24	1
3	40.120.0.0/16	2
4	160.0.0.0/2	3
5	111.11.0.0/16	3
6	211.57.0.0/16	4
7	0.0.0.0/2	4
8	0.0.0.0/0	5

For each destination addresses below, write the output port and the list all the matching table entries.

address	output port	matching entries
211.57.1.69		
10.142.226.44		
98.7.2.71		
200.100.2.1		
40.120.207.167		
211.57.20.11		
211.57.21.10		

(10')

► **Exercise 21.** Consider the following network

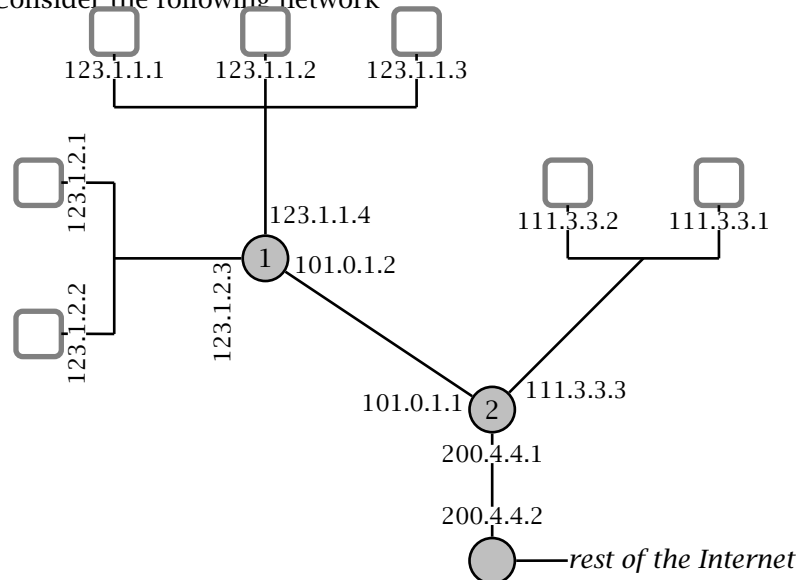

Write the forwarding tables of routers 1 and 2. Assume longest-prefix matching. Assume also that each subnet holds a block of 256 addresses. In writing the forwarding tables, identify each output port directly with their IP address. (15')

► **Exercise 22.** Consider the following simple network topology where routers use a distance-vector routing protocols

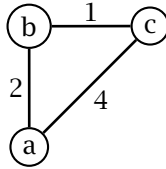

For simplicity, assume all routers start at time 0, that routing messages (i.e., distance vectors) are sent out by routers every 10 seconds, and that they are received by neighbor routers after one second. Write the first iterations of the distance-vector routing algorithm, at times 0, 10, ..., until the protocol converges to a stable state. For each iteration, list the routing tables of each router. (15')

► **Exercise 23.** Consider three autonomous systems A, B, and C, connected in the following AS-level topology

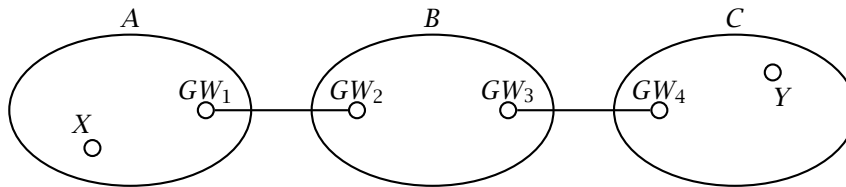

Illustrate the idea of hierarchical routing in the particular case of the Internet by describing the process by which an IP packet would be routed from a source router X in A to a destination router Y in C. For each step, briefly discuss which routing information is used, which protocol determines that routing information, and how that routing information is transmitted to the router. (10')

► **Exercise 24.** Briefly describe what kind of routing information is exchanged by two BGP peers. In particular, explain what information allows BGP to detect and avoid routing loops. (5')

► **Exercise 25.** Alice and Bob plan to communicate privately using a one-time pad encryption scheme, and therefore agree on a secret key $k = 10100100111100111010011010001101$. The first message that Alice wants to send is "CIAO". Alice and Bob use an insecure channel (e.g., a simple TCP connection). Therefore, Eve can intercept every transmission. Assuming that Alice uses the ASCII encoding, and that the codes for the letters C, I, A, and O are 67, 73, 65, and 79, respectively, what does Eve see when Alice sends her first message? How many more bytes can Alice and Bob exchange securely? Justify your answers. (10')

► **Exercise 26.** You are sending an e-mail message to *dude@duder.org*. The mail exchange server for the *duder.org* domain is *mail.duder.org*. Detail the SMTP conversation between your mailer and *mail.duder.org*. Write every SMTP message exchanged by your mailer and the server. Assume that *dude@duder.org* is a valid address for *mail.duder.org* and that no communication or server errors occur. (20')

► **Exercise 27.** Answer the following questions. Briefly explain the functionality of the ACK flag in the TCP header. (5')

Do IPv4 headers and IPv6 headers have any fields in common? If any, describe the function of the common fields? (5')

Do TCP headers and UDP headers have any fields in common? If any, describe the function of the common fields? (5')

► **Exercise 28.** Answer the following questions. Consider a TCP connection between host X and host Y. Suppose host X sends two TCP segments, one after the other, to host Y, with sequence numbers 200 and 500, respectively. What happens if the first segment is lost but the second segment arrives at Y? Does Y send an acknowledgment? If so, what is the sequence number of the acknowledgment? How many data bytes are in the first datagram? Briefly justify your answers. (5')

Briefly describe the idea of *classless interdomain routing (CIDR)*. Give an example of a "classless" subnet address. Why is this addressing scheme important in Internet routing? (5')

Suppose an IP datagram goes from its source X to its destination Y through four routers. How many interfaces does the datagram go through? How many times does the datagram cause a router to look up its forwarding tables? Justify your answers. Assume no fragmentation. (5')

► **Exercise 29.** List three HTTP methods. For each method, briefly explain its main purpose and give a valid server response. (10')

► **Exercise 30.** Consider a non-recursive DNS lookup for the A record of *www.elet.polimi.it* executed from within the *unisi.ch* domain. Give a list of plausible DNS servers contacted by your local DNS resolver. You do not need to list the local DNS server. For each server, write a plausible query and response (in English—don't bother using the exact DNS format). (10')

► **Exercise 31.** A TCP segment with sequence number 2345 carries the following HTTP request:

```
HTTP/1.0 404 Not Found
Content-Type: text/html
Content-Length: 200
```

```
<html><body>Not Found!
...more html text here...
</body></html>
```

What is the sequence number of the next segment? Briefly justify your answer. (Remember that all HTTP header lines end with a CRLF sequence.) (10')

► **Exercise 32.** A Web browser makes an HTTP/1.0 request over TCP to a web server to retrieve a 2Kb object (e.g., a web page). The network between the browser and the server has an MTU of 1500 bytes, a latency of 100ms, and a throughput of 100KB/s. List all IP datagrams for the connection. For each datagram, describe the most important header fields of each protocol (IP, TCP, and HTTP). Assume no congestion, no network errors, and no fragmentation. Also, how long does it take for the browser to retrieve the entire object? Justify your answer. (20')

► **Exercise 33.** Consider a router in an IPv4 network using longest-prefix matching. The router has the following forwarding table:

entry	destination	interface
1	98.7.1.0/16	1
2	139.57.20.0/24	1
3	40.120.0.0/16	2
4	160.0.0.0/2	3
5	111.11.0.0/16	3
6	139.57.0.0/16	4
7	0.0.0.0/2	4
8	0.0.0.0/0	5

For each destination addresses below, write the output port and the list all the matching table entries.

address	output port	matching entries
139.57.1.69		
10.142.226.44		
98.7.2.71		
162.100.2.1		
40.120.207.167		
139.57.20.11		
139.57.21.10		

► **Exercise 34.** Consider the following networks: (1) a packet-switched network with 16-bit addresses and a total of 1000 nodes, and (2) a virtual-circuit network with 8-bit virtual-circuit identifiers and 30 active virtual circuits. For each network, write and describe the “signature” of the

forwarding function. That is, describe its domain (input set) and range (output set). Assuming that the forwarding function is implemented through a simple table containing one entry per input value. For each network, tell how many entries are in the forwarding table. Briefly justify your answer. (10')

► **Exercise 35.** Briefly describe a *block cipher*. In particular, describe the parameters that define the signature of a block cipher. (5')

► **Exercise 36.** Given the following network topology, specify the forwarding function of node *a* in the form of a simple forwarding table. Specify the output interfaces using the identifier of the next-hop router. Does the same forwarding table for node *f* have more, less, or the same number of entries? Briefly justify your answer.

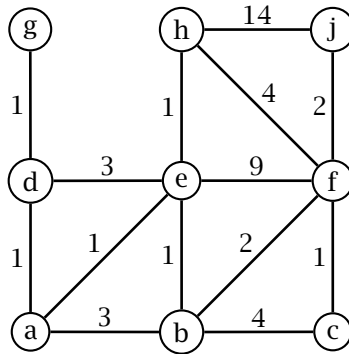

(15')

► **Exercise 37.** Compare and contrast *distance-vector* and *link-state* routing. In particular, describe the information that routers exchange, and the kind of processing they perform locally. (10')

► **Exercise 38.** For each one of the following subnet addresses, give an example of an IP address that can be assigned to that subnet, and one that can not.

subnet	IP address in subnet	IP address outside subnet
67.56.0.0/16		
121.232.111.128/25		
121.34.56.64/30		
128.131.9.0/16		
128.131.10.0/16		
128.0.0.0/8		
93.20.10.0/28		
128.242.138.0/18		
200.220.76.0/24		
200.220.0.0/12		

(10')

► **Exercise 39.** Consider three autonomous systems *A*, *B*, and *C*, connected in the following AS-level topology

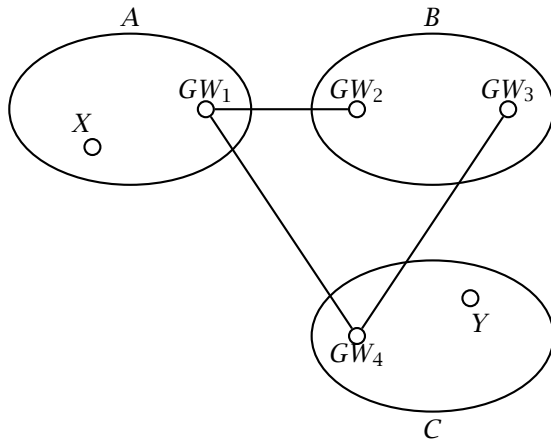

Illustrate the idea of hierarchical routing in the particular case of the Internet by describing the process by which an IP packet would be routed from a source router X in A to a destination router Y in C . For each step, briefly discuss which routing information is used, which protocol determines that routing information, and how that routing information is transmitted to the router. (15')

► **Exercise 40.** The web object located at <http://exacttime.ch/now> gives the time of day.

Question 1: Write an HTTP 1.0 request to read the current time, and a plausible response from the server. Write the request and the response as (ASCII) text. If you need to express non-text bytes, then write a backslash '\ ' and then either their numeric value or a short textual description of the character. (5')

Question 2: Write an HTTP 1.1 request for the same object <http://exacttime.ch/now> where the client attempts to keep the connection open. Again write both the client request and the server response. What kind of cache-control should the server specify in its reply? Justify your answer. (5')

► **Exercise 41.** Briefly describe at least four types of *resource records* in the Domain Name System. (10')

► **Exercise 42.** Your computer uses a DNS resolver connected on your local-area subnet where the latency is $L_{in} = 5\text{ms}$. Your subnet is connected to the rest of the Internet through a single link that introduces a latency of 200ms. Suppose you click on a link to <http://www.gnu.org/>. What is the minimum amount of time before your browser can start to display the web page? Ignore the rendering time and other CPU latencies. Assume that the address of www.gnu.org is not in the cache of your host or your local DNS. Justify your answer. (10')

► **Exercise 43.** An e-commerce web site needs to keep track of per-user shopping sessions. How can that be done using HTTP 1.0? Describe this mechanism through an example in which two different users are active at the same time. Write every user request and every server response in your example. (10')

► **Exercise 44.** Can user sessions be implemented in HTTP 1.1 with persistent connections? If so, show how through an example, writing at least two requests/replies for the same session. If not, justify your answer through a counter-example in which a persistent connection could represent more than one user. (10')

► **Exercise 45.** Design the high-level interface of a web-mail system. That is, a mail system where the client communicates with the server using HTTP. In particular, specify how you would you implement a *send* function, to send an e-mail message, a *read-folders* function, to get a list of folders, a *read-folder-summary* function to get the list of messages in a folder, a *read* function, to read a given message within a given folder. Also, how can you implement a *notification* function that tells you you have received a message. (20')

► **Exercise 46.** You are setting up the Internet resources of an organization called *Addio Lugano Bella*.

Question 1: Can you have your web site at <http://addio.luganobella.org/> and, at the same time, have an e-mail address such as michael@addio.luganobella.org? Justify your answer. (5')

Question 2: Can you do that with two different hosts, one running a web server and one running a mail server? If so, explain how. If not, give a counter-example. (5')

► **Exercise 47.** Someone composes the following e-mail message

From: The Dude <duder@bowlingalley.net> Subject: the story of my rug To: Jeffrey Lebowski <jeffrey@lebowski.com> Cc: Walter <walter@bowlingalley.net> Bcc: Maude <maude@lebowski.com>
Just so you know, I think I saw Bunny last night... Dude.

Write the SMTP commands that the user agent issues to send this message. (10')

► **Exercise 48.** The network connection between Host A and Host B has a latency of $L = 200\text{ms}$, a throughput $T = 500\text{KB/s}$, and a maximum segment size $MSS = 1460b$. How long does it take for TCP to transfer a 10Kb file from A to B? Assume no errors, no packet loss, and no packet duplication. Justify your answer. (10')

► **Exercise 49.** The network connection between Host A and Host B has a latency of $L = 500\text{ms}$, a throughput $T = 100\text{KB/s}$, and a maximum segment size $MSS = 1460b$. How long does it take for TCP to reach the maximum throughput for that connection? Assume no errors, no packet loss, and no packet duplication. Justify your answer. (10')

► **Exercise 50.** The network connection between Host A and Host B admits TCP segments that can carry up to 512 bytes of data. Host A connects to Host B, transfers 2000 bytes, and closes the connection.

Question 1: List all the TCP segments exchanged between A and B in the presence of a perfectly reliable network (no errors, no losses, no duplicates). For each segment, write source and destination port (choose some values), sequence number, ack number, and all the active flags. (10')

Question 2: List all the TCP segments exchanged between A and B in case the network loses two segments. Choose which segments are dropped among the ones that carry data. Again, for each segment, write source and destination port (choose some values), sequence number, ack number, and all the active flags. Also, clearly mark the two dropped segments. (10')

► **Exercise 51.** Briefly describe the state maintained by a sender *Go-Back-N*. How does the sender update its local state in case (1) a timeout occurs, and (2) a packet is received correctly. (10')

► **Exercise 52.** A router has output interfaces with a buffer (queue) that can hold up to 64 packets and with links each capable of transmitting up to 10000 packets per second. The router has 4 input interfaces, each one receiving an average of 6000 packets per second. Suppose that at some point, and for a long period of time, all traffic happens to be forwarded to the same output interface.

Question 1: Assuming that both input ports and switch fabric are capable of handling the input flow, is the router congested during this period? If so, what is the probability that a packet be dropped? Assume the router uses a “drop-tail” policy. Justify your answer. (5')

Question 2: Assume that each input port is capable of receiving and processing 10000 packets per second, and that the switching fabric can process 20000 packets per second. Assume also that the router processes packets in a first-come first-served manner. What is the expected latency during this period? Justify your answer. (5')

► **Exercise 53.** A router has four output interfaces each with a buffer that can hold up to 64 packets and with a link capable of transmitting up to 6000 packets per second. Suppose that at time $t = 0$, when all buffers are empty, the router starts receiving a steady flow of 20000 packets per second from its input interfaces. Assume that both input ports and switch fabric are capable of handling the input flow. Of all the input packets, 40% go to output interface 1, 30% to interface 2, 20% to interface 3, and 10% to interface 4. Can the router sustain this kind of traffic without dropping packets? If so, what is the expected length of the packet queue on each output interface? If not, what is the expected time t' when the router will start dropping packets? Justify your answer. (10')

► **Exercise 54.** Describe the IPv6 packet format. Briefly explain the function of each header field. (Hint: if you don't remember all the fields, at least try to focus on the most important ones.) (5')

► **Exercise 55.** A router receives an IPv4 datagram with the following header fields: *datagram-length=1500, header-length=20, identifier=1234, fragmentation-offset=300, more-fragments=1*. The router decides that it must forward this datagram through an interface with an MTU of 512 bytes. To do that, the router must fragment the datagram. Explain how the router does that. In particular, for each fragment, write all the relevant header fields. (10')

► **Exercise 56.** For each one of the following network (prefix) addresses, write the corresponding range of addresses.

<i>subnet prefix-address/prefix-length</i>	<i>range</i>
34.254.21.128/25	
128.129.242.160/30	
192.168.0.0/16	
231.111.10.160/27	
68.103.128.0/24	
68.103.128.0/22	
127.0.0.1/8	
230.1.0.192/27	
224.0.0.0/4	
0.0.0.0/0	

(10')

► **Exercise 57.** For each one of the following network (prefix) addresses, write the corresponding address and mask (i.e., address/mask)

<i>subnet prefix-address/prefix-length</i>	<i>range</i>
34.254.21.128/25	
128.129.242.160/30	
192.168.0.0/16	
231.111.10.160/27	
68.103.128.0/24	
68.103.128.0/22	
127.0.0.1/8	
230.1.0.192/27	
224.0.0.0/4	
0.0.0.0/0	

(5')

► **Exercise 58.** Consider the following AS-level topology and the given allocation of addresses

AS3 128.138.0.0/16
200.23.128.0/18

AS1 200.23.192.0/18
39.81.36.0/22
39.81.40.0/22
39.81.44.0/22

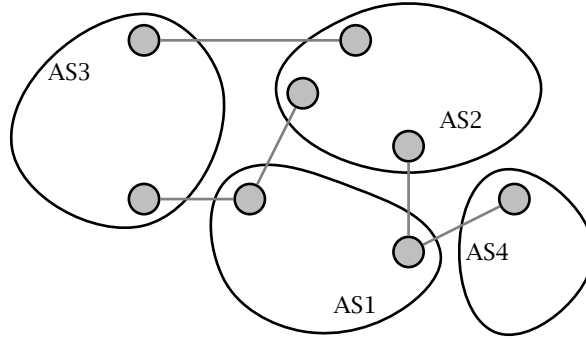

AS2 68.10.20.0/24
87.13.192.0/27
128.30.0.0/16

AS4 87.13.128.0/27
100.91.45.0/24
39.81.32.0/22

Write all the BGP route advertisements produced by each one of the autonomous systems. For each advertisement write only destination and AS path. Assume that autonomous systems are always willing to accept and forward route advertisements. (Hint: remember that addresses should be combined in router advertisements.) (20')

► **Exercise 59.** Give an example in which two ISPs advertise address prefixes that define overlapping ranges of addresses (in fact subsets). Briefly explain how longest-prefix matching is used to disambiguate the forwarding function. Draw the network topology, the address allocation, and the route advertisements. Briefly explain why doing this is useful. (10')

► **Exercise 60.** Consider the following network where routers use a distance-vector routing protocols

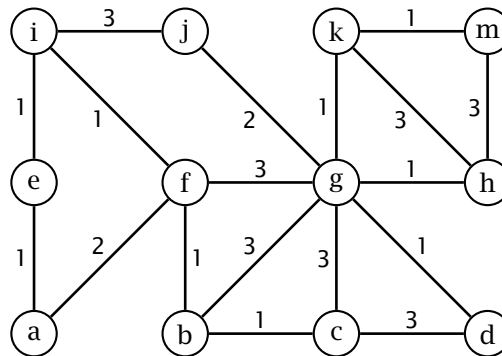

Question 1: Write all the routing information maintained by router f at a time when the routing protocol has converged to a stable state. (Hint: this includes router f 's distance vector as well as the distance vectors received from its neighbors.) (15')

Question 2: At a later time, the cost (e.g., latency) of the (f, g) link raises to 10. Write the distance vector that router f sends out after this link-cost change. (5')

► **Exercise 61.** Describe a *block cipher* and a *stream cipher*.

Question 1: Write the mathematical definition of a block cipher (i.e., its domain and range), and briefly describe its desired properties. (5')

Question 2: Write the mathematical definition of a stream cipher, and briefly describe its desired properties. (5')

► **Exercise 62.** Alice wants to send Bob a private message m of $N = |m|$ bits. Alice and Bob share a secret 128-bit key K . Briefly explain how Alice would encrypt the message and how Bob would recover the original message from the ciphertext. Specify which cryptographic primitive(s) they would use, and how. (10')

► **Exercise 63.** Below are four TCP packets captured on the network at more or less the same time.

(1)	<table border="1"><tr><td colspan="2"><i>src-address: 128.138.242.241</i></td></tr><tr><td colspan="2"><i>dest-address: 66.78.102.32</i></td></tr><tr><td><i>src-port: 3241</i></td><td><i>dest-port: 5432</i></td></tr><tr><td colspan="2"><i>seq-num: 2000</i></td></tr><tr><td colspan="2"><i>ack-num: 0</i></td></tr><tr><td colspan="2">...</td></tr><tr><td colspan="2">...</td></tr></table>	<i>src-address: 128.138.242.241</i>		<i>dest-address: 66.78.102.32</i>		<i>src-port: 3241</i>	<i>dest-port: 5432</i>	<i>seq-num: 2000</i>		<i>ack-num: 0</i>		
<i>src-address: 128.138.242.241</i>															
<i>dest-address: 66.78.102.32</i>															
<i>src-port: 3241</i>	<i>dest-port: 5432</i>														
<i>seq-num: 2000</i>															
<i>ack-num: 0</i>															
...															
...															
(3)	<table border="1"><tr><td colspan="2"><i>src-address: 128.138.242.241</i></td></tr><tr><td colspan="2"><i>dest-address: 66.78.102.32</i></td></tr><tr><td><i>src-port: 5432</i></td><td><i>dest-port: 3241</i></td></tr><tr><td colspan="2"><i>seq-num: 2001</i></td></tr><tr><td colspan="2"><i>ack-num: 0</i></td></tr><tr><td colspan="2">...</td></tr><tr><td colspan="2">...</td></tr></table>	<i>src-address: 128.138.242.241</i>		<i>dest-address: 66.78.102.32</i>		<i>src-port: 5432</i>	<i>dest-port: 3241</i>	<i>seq-num: 2001</i>		<i>ack-num: 0</i>		
<i>src-address: 128.138.242.241</i>															
<i>dest-address: 66.78.102.32</i>															
<i>src-port: 5432</i>	<i>dest-port: 3241</i>														
<i>seq-num: 2001</i>															
<i>ack-num: 0</i>															
...															
...															

(2)	<table border="1"><tr><td colspan="2"><i>src-address: 66.78.132.200</i></td></tr><tr><td colspan="2"><i>dest-address: 128.138.242.241</i></td></tr><tr><td><i>src-port: 5432</i></td><td><i>dest-port: 3241</i></td></tr><tr><td colspan="2"><i>seq-num: 2000</i></td></tr><tr><td colspan="2"><i>ack-num: 0</i></td></tr><tr><td colspan="2">...</td></tr><tr><td colspan="2">...</td></tr></table>	<i>src-address: 66.78.132.200</i>		<i>dest-address: 128.138.242.241</i>		<i>src-port: 5432</i>	<i>dest-port: 3241</i>	<i>seq-num: 2000</i>		<i>ack-num: 0</i>		
<i>src-address: 66.78.132.200</i>															
<i>dest-address: 128.138.242.241</i>															
<i>src-port: 5432</i>	<i>dest-port: 3241</i>														
<i>seq-num: 2000</i>															
<i>ack-num: 0</i>															
...															
...															
(4)	<table border="1"><tr><td colspan="2"><i>src-address: 128.138.242.241</i></td></tr><tr><td colspan="2"><i>dest-address: 66.78.132.200</i></td></tr><tr><td><i>src-port: 3241</i></td><td><i>dest-port: 5432</i></td></tr><tr><td colspan="2"><i>seq-num: 1</i></td></tr><tr><td colspan="2"><i>ack-num: 2300</i></td></tr><tr><td colspan="2">...</td></tr><tr><td colspan="2">...</td></tr></table>	<i>src-address: 128.138.242.241</i>		<i>dest-address: 66.78.132.200</i>		<i>src-port: 3241</i>	<i>dest-port: 5432</i>	<i>seq-num: 1</i>		<i>ack-num: 2300</i>		
<i>src-address: 128.138.242.241</i>															
<i>dest-address: 66.78.132.200</i>															
<i>src-port: 3241</i>	<i>dest-port: 5432</i>														
<i>seq-num: 1</i>															
<i>ack-num: 2300</i>															
...															
...															

Which ones belong to the same TCP connection? Briefly justify your answer. Also, write another plausible packet belonging to the same connection. (10')

- ▶ **Exercise 64.** What is the theoretical maximum number of TCP connections allowable between two given hosts at the same time? Briefly justify your answer. (5')
- ▶ **Exercise 65.** List and briefly describe the primary attributes of a BGP advertisement. (5')
- ▶ **Exercise 66.** An IPv4 header contains a 16-bit packet identifier. What is the purpose of this identifier? Is there an equivalent header field in IPv6? If so, which one is it? If not, explain why not. (5')
- ▶ **Exercise 67.** The HTTP 1.1 protocol requires that clients specify at least one header in their requests. Which header is it? Explain its purpose and the reason why HTTP 1.1 requires it. (5')
- ▶ **Exercise 68.** Answer “yes” or “no” to the following questions.
 - Question 1:* Is it possible for an IPv6 datagram to contain a TCP segment?
 - Question 2:* Does the UDP header contain a flag called “more-fragments”?
 - Question 3:* Does UDP provide any ordered-delivery guarantee?
 - Question 4:* Is there any flags in the TCP header that signals network congestion?
 - Question 5:* Does TCP support bi-directional communication? (10')
- ▶ **Exercise 69.** TCP is used in a network with $MTU = 512B$ to transfer a 1000-bytes file. Briefly list all the segments necessary to open the connection, send the 1000-bytes file, and close the connection. For each segment, write source and destination port (choose some values), sequence number, ack number, and all the active flags. You may assume that the network is perfectly reliable. (20')
- ▶ **Exercise 70.** A network link has a latency $L = 600ms$ and is perfectly reliable. What is the minimum throughput T (in bytes per second) necessary to transmit a 70KB file in less than two seconds? Briefly justify your answer. (5')
- ▶ **Exercise 71.** A datagram network link has a latency $L = 600ms$, throughput $T = 50KB/s$, and a maximum segment size $MTU = 1KB$. How long does it take to transmit a 50KB file using a stop-and-wait transport protocol in the absence of errors? Briefly justify your answer. (5')
- ▶ **Exercise 72.** A router in an IPv4 network using longest-prefix matching has the following forwarding table:

entry	destination	interface
1	39.129.0.0/16	1
2	139.57.20.128/25	1
3	39.129.128.0/18	2
4	66.160.0.0/11	3
5	222.22.0.0/16	3
6	139.57.0.0/16	4
7	66.192.0.0/10	4
8	0.0.0.0/0	5
9	66.224.0.0/11	6

Question 1: For each destination address below, write the output port and the list all the matching table entries.

(10')

address	output port	matching entries
139.57.1.69		
66.250.226.44		
98.7.2.71		
162.100.2.1		
40.120.207.167		
139.57.20.11		
139.57.21.10		

Question 2: Write all the inclusion relations between table entries. (An entry x includes another entry y if x matches a superset of the addresses matched by y .)

(10')

► Exercise 73. Consider the following network topology.

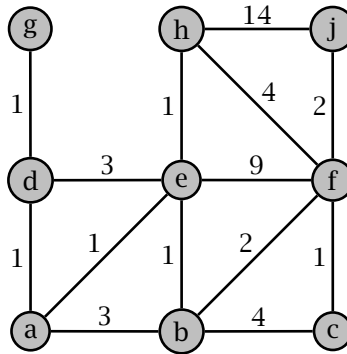

Question 1: Assuming that routers use a link-state routing protocol, write the link-state advertisement announced by router b . Which nodes receive this link-state advertisement? Explain and justify your answer.

(5')

Question 2: Now assume a distance-vector protocol. Write the distance vector announced by router b . Which nodes receive this distance vector? Explain and justify your answer.

(5')

► Exercise 74. Your computer uses a local, iterative DNS resolver. How many DNS packets does your computer send out to resolve the address of `www.cs.colorado.edu`? Specifically, list every DNS request and plausible replies. Assume that your computer is outside the `colorado.edu` domain, that the network is reliable, and that the given name is not cached by any name server.

(10')

► Exercise 75. Alex (`alex@buonasera.com`) writes the message “ciao, come stai?” to `antonio@ciao.com` and also sends a “blind carbon-copy” (Bcc) to `alberto@arrivederci.com`. Write the SMTP exchange between Alex’s user agent and his mail server.

(10')

► **Exercise 76.** *archie@carygrant.com* opens his MUA and sends an email to *grace@principaute.mc*. Grace opens her MUA and retrieves the new mail in her inbox, thus finding Archie's message.

Question 1: Describe all the the communication at the application level taking place between:

- Archie's MUA running SMTP on host `host-151-100-17-8.dialup.aol.com`
- the DNS resolver library that is part of the OS on the same host
- the local DNS on `local-dns.dialup.aol.com` that serves queries for hosts in the domain `dialup.aol.com`
- The mail server `smtp.carygrant.com`

Draw a box for each of these end-systems; describe the requests and replies as arrows, and label them with a number to describe the sequence of different communications, and with a quick description of what's exchanged (e.g. what *resource records* are sent in case of a DNS reply, and so on). (10')

Question 2: Do the same for the following hosts:

- Grace's MUA running POP3 on host `majesty.principaute.mc`
- the DNS resolver library that is part of the OS on the same host
- the local DNS on `dns.principaute.mc` that serves queries for hosts in the domain `principaute.mc`.
- The mail server `pop.principaute.mc`

Assume that Grace's MUA runs in retrieve-and-delete mode. (10')

► **Exercise 77.** A cracker gains control of the host running the local DNS system of your ISP, and runs a modified version of the DNS server, that artificially keeps forever the following Resource Record:

(`ebanking.ubs.com`, 108.20.213.23, IN, A)

(The IP 108.20.213.23 is the address of a web server administered by the cracker that shows a fake UBS login page, made for the purpose of stealing passwords for bank accounts.)

Question 1: In what case this situation may be harmful? How can a client avoid to be directed to the fake page? Motivate your answer. (5')

Question 2: Consider the situation in which the fake record is

(`ubs.com`, `evildns.piratedomain.net`, IN, NS)

where `evildns.blackhat.net` is a DNS server containing the previous record. Does the solution to avoid the problem given in the previous exercise still work? Motivate your answer. (5')

► **Exercise 78.** Consider a web page consisting of 4 JPEG images of 10Kb each. The size of the HTML code is 4K. The average latency induced by a single TCP 3-way handshake is 10ms, the average latency due to closing the connection is 5ms, and the average latency induced by the DNS query to get the IP address of the web server is 200ms. Assuming that the web server is accessible through a corporate point-to-point link that allows a throughput of 1MB/s, and assuming that the rendering time is negligible, compute the average time it takes for the browser to display the page in the following cases.

Question 1: The web server does not support persistent connections. (10')

Question 2: The web server supports persistent connections without pipelining. (10')

Question 3: The web server supports persistent connection with pipelining. (10')

► **Exercise 79.** Below are four TCP packets captured on the network at more or less the same time.

(1)	<i>src-address: 34.198.10.3</i>	
	<i>dest-address: 101.124.102.32</i>	
	<i>src-port: 3241</i>	<i>dest-port: 5432</i>
	<i>seq-num: 2000</i>	
	<i>ack-num: 0</i>	
	...	
...		
(3)	<i>src-address: 34.198.10.3</i>	
	<i>dest-address: 101.124.132.200</i>	
	<i>src-port: 3241</i>	<i>dest-port: 5432</i>
	<i>seq-num: 1</i>	
	<i>ack-num: 2300</i>	
	...	
...		

(2)	<i>src-address: 34.198.10.3</i>	
	<i>dest-address: 101.124.102.32</i>	
	<i>src-port: 5432</i>	<i>dest-port: 3241</i>
	<i>seq-num: 2001</i>	
	<i>ack-num: 0</i>	
	...	
...		
(4)	<i>src-address: 101.124.132.200</i>	
	<i>dest-address: 34.198.10.3</i>	
	<i>src-port: 5432</i>	<i>dest-port: 3241</i>
	<i>seq-num: 2000</i>	
	<i>ack-num: 0</i>	
	...	
...		

Which ones belong to the same TCP connection? Briefly justify your answer. Also, write another plausible packet belonging to the same connection. (10')

► **Exercise 80.** A network link has a latency $L = 800\text{ms}$ and is perfectly reliable. What is the minimum throughput T (in bytes per second) necessary to transmit a 60KB file in less than two seconds? Briefly justify your answer. (5')

► **Exercise 81.** A datagram network link has a latency $L = 500\text{ms}$, throughput $T = 50\text{KB/s}$, and a maximum segment size $MSS = 1\text{KB}$. How long does it take to transmit a 50KB file using a stop-and-wait transport protocol in the absence of errors? Briefly justify your answer. (5')

► **Exercise 82.** Describe how *congestion control* is implemented within TCP. In particular, describe (a) how TCP detects congestion, (b) what mechanism it uses to control the sender rate, and (c) how it modulates the sender rate. (20')

► **Exercise 83.** List all the headers of a UDP datagram. Briefly describe the functionality of each header, specifically referring to their role as transport-level features. (5')

► **Exercise 84.** Describe the IPv4 packet format. Briefly explain the function of each header field. If you don't remember all the fields, at least try to focus on the most important ones. (10')

► **Exercise 85.** Consider the high-level architecture of a router.

Question 1: Describe the architecture of an input port and an output port of a router. Briefly describe the function of each component. (5')

Question 2: Describe at least two different scenarios in which a router drops packets. For each scenario, list the performance characteristics of the router (i.e., throughput of each component) and the characteristics of the input/output traffic. (5')

► **Exercise 86.** A router has 4 input interfaces and n output interfaces. The input lines have a maximum individual speed of 20000 packets per second. Specify the throughput of the other components of the router in such a way that no packet queues are needed. Do the results depend on the number of output interfaces? If so, say how. If not, say why. (5')

► **Exercise 87.** A router has one input interface and two output interfaces. The input port can receive and process $\lambda = 10000$ packets per second. The transmission rate of the two output ports are λ' and λ'' , respectively. The router's manufacturer designed the router so that $\lambda = \lambda' + \lambda''$. Compute the values of λ' and λ'' , assuming that:

- the port with packet throughput λ' is connected to a link with throughput $t' = 10\text{MB/s}$, with $MTU = 1\text{KB}$ (Assume $1\text{K} = 1024$)
- the port with packet throughput λ'' is connected to a link with throughput $t'' = 5\text{MB/s}$, with $MTU = 512\text{B}$

(10')

► **Exercise 88.** Consider the following network topology at time $t = 0$:

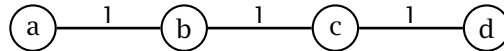

The four routers compute their routing tables using the distance-vector algorithm. At time $t' > 0$, after the algorithm has converged, the link connecting a to b breaks down, resulting in this topology:

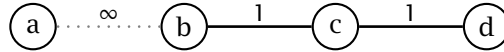

Question 1: Write the distance $D_x(a)$ from router x to router a , for $x \in \{b, c, d\}$, computed by the distance-vector algorithm at each router, for at least six iterations of the algorithm. (10')

Iteration	$D_b(a)$	$D_c(a)$	$D_d(a)$

Question 2: Compare and contrast the way distance-vector and link-state routing deal with these cases. In particular, say which algorithm would have a faster reaction time to a link failure? Justify your answer. (5')

► **Exercise 89.** Express the following address ranges using the subnet prefix notation. If a range can not be represented with the prefix notation, write “N.A.”

range	subnet prefix-address/prefix-length
88.99.100.128-88.99.100.191	
171.220.142.64-171.220.142.255	
128.138.50.0-128.138.51.255	
204.88.0.0-204.90.255.255	
108.80.0.0-108.87.255.255	
128.128.0.0-128.159.255.255	

For each valid prefix you wrote above, write the corresponding address/mask expression (10')

► **Exercise 90.** A small ISP administers the IPv4 address range defined by the prefix 41.195.32.0/24. The ISP has three clients. Client A requires 125 addresses, clients B and C require up to 60 addresses each. Allocate the address range of the ISP to the three clients. In particular, write the network address (address prefix) of the subnet of each client. (10')

► **Exercise 91.** Autonomous system AS7 has a single gateway router R , and receives the following BGP advertisements.

Network prefix	AS-PATH
81.128.242.0/24	AS2, AS1
81.128.243.0/24	AS2, AS1
81.128.0.0/16	AS2, AS1
199.203.128.0/22	AS5, AS3, AS1
199.203.136.0/21	AS4, AS3, AS1
199.203.132.0/22	AS4, AS3, AS1
81.128.128.0/22	AS6, AS2, AS1
81.128.136.0/21	AS6, AS2, AS1
138.138.132.0/22	AS6, AS2, AS1

Question 1: Write a possible AS-level topology (5')

Question 2: Write the minimal set of entries in the forwarding table of router R for its external interface (i.e., the interface that connects R to the outside of AS7). (10')

► **Exercise 92.** Consider a block cipher $E_1 : \{0, 1\}^k \times \{0, 1\}^n \rightarrow \{0, 1\}^n$ with a key size of $k = 32$ bits and a block size of $n = 128$ bits. Would you use E_1 to secure your most secret communications? Briefly justify your answer. (5')

► **Exercise 93.** Consider a block cipher $E_2 : \{0, 1\}^k \times \{0, 1\}^n \rightarrow \{0, 1\}^n$ with a key size of $k = 128$ key bits and a block size of $n = 2$ bits.

Question 1: Would you use E_2 to secure your most secret communications? Briefly justify your answer. (5')

Question 2: An ℓ -bit plaintext message m is encrypted with E_2 in cipher-block chaining (CBC) mode. You are given the ciphertext x but not the encryption key. Could you recover the plaintext message in a reasonable amount of time? How? How many possible plaintext messages exist that would result in the given ciphertext x ? Briefly justify your answers. (15')

► **Exercise 94.** Given the following network topology where link costs represent latencies in seconds. At time $t = 0$, node a sends a broadcast datagram d . Assuming that the network implements a controlled-flood broadcast, write all the packets transmitting d across the network. For each packet, write the start time, arrival time, start node, arrival node. Assume that processing time at each node is negligible.

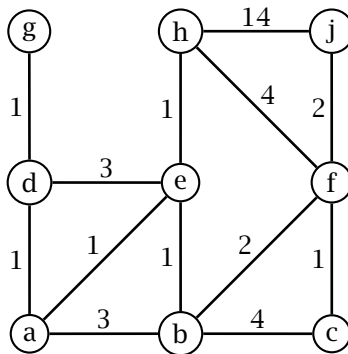

(20')

► **Exercise 95.** A router x issues the following link-state advertisement $LSA_x = \{(a, 1), (b, 1), (d, 2)\}$ and receives the following other advertisements, where letters (a, b, \dots) represent router addresses.

- $LSA_g = \{(d, 2), (h, 5), (f, 1)\}$
- $LSA_e = \{(h, 2), (f, 4), (a, 1)\}$
- $LSA_f = \{(g, 1), (d, 3), (b, 2), (e, 4), (h, 4)\}$
- $LSA_b = \{(a, 2), (x, 1), (d, 1), (f, 2)\}$
- $LSA_d = \{(x, 2), (b, 1), (f, 3), (g, 2)\}$
- $LSA_a = \{(e, 1), (b, 2), (x, 1)\}$
- $LSA_h = \{(e, 2), (f, 1), (g, 5)\}$

Write the forwarding table of router x . Justify your answer by explaining briefly how link-state routing works. (20')

- **Exercise 96.** A guy who calls himself “The Dude” sends a message to his friend Donny, sending also a “carbon-copy” (Cc) to his other friend Walter, and also sending a “blind” carbon copy (Bcc) to his lady friend, Maude. The message is the following

From: the.dude@elduderino.org
To: donny@bowling-alley.net
Cc: walter@bowling-alley.net
Bcc: maude@v-artist.org

Hello Donny,
 You were throwing rocks last night!
 See you tomorrow,
 The Dude

Write all the SMTP sessions necessary to deliver the message, including the session between the Dude’s user agent and the Dude’s SMTP server (mail.elduderino.org). (20’)

- **Exercise 97.** You point your web browser to a site called *www.pizzaefichi.ch*. Your computer uses a local DNS resolver to find the address of *www.pizzaefichi.ch*. Suppose your resolver does not know the address of *www.pizzaefichi.ch* but it has in cache the address of a name server for the *ch* domain. Describe all the DNS requests, and plausible responses, issued by your resolver and by external name servers, respectively. (20’)

- **Exercise 98.** Describe the function of the congestion window used by TCP. Also describe the mechanisms by which TCP controls the congestion window. (20’)

- **Exercise 99.** Consider a link with round-trip time $2L = 200\text{ms}$ and throughput $T = 200\text{KB/s}$.

Question 1: Suppose the link is used by a *stop-and-wait* transport protocol with maximum segment size $S = 4\text{KB}$. What is the maximum utilization factor for the link? Justify your answer. (*Hint:* the utilization factor is the ratio between the amount of time the link transmits, and the amount of idle time.) (5’)

Question 2: Suppose the link is used by a *go-back-n* transport protocol with maximum segment size $S = 4\text{KB}$. What is the (sender) window size that maximizes the utilization factor for the link? Justify your answer. (5’)

- **Exercise 100.** A sender host wants to transmit a 20000 bytes file using TCP/IP. The host is connected through a link with a maximum packet size of $S_p = 1500$ bytes. What is the minimum number of bytes that the sender must push through the network. Assume that an IPv4 header uses 20, and that a TCP header uses 20 bytes. Justify your answer. (5’)

- **Exercise 101.** Consider a link with round-trip time $2L = 100\text{ms}$, throughput $T = 1\text{MB/s}$, and maximum packet size $S = 1\text{KB}$. Suppose this link is used by a transport protocol with a fixed window size of W bytes. What is minimum possible latency to transmit a 100Kb file? What is the minimum window size W that achieves this minimum latency? Justify your answer. (5’)

- **Exercise 102.** Consider a Web document that contains very sensitive information (e.g., an on-line medical report). How can the server ask the client *not* to store a copy of the document locally? Explain this method by writing an HTTP request for that document and the corresponding server response. (5’)

- **Exercise 103.** Briefly describe the most important attributes of a BGP route-advertisement. (5’)

- **Exercise 104.** Consider the following network where each link has a total throughput of 1MB/s.

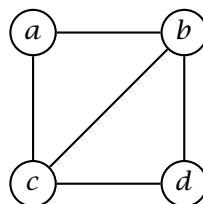

Question 1: What is the absolute maximum throughput between two applications running on hosts *a* and *b*, respectively? Briefly justify your answer. (5')

Question 2: Assuming the network is circuit-switched and each link supports up to 2 circuits at the same time, how many pairs of applications can communicate simultaneously from *a* to *d*? From *a* to *b*? From *b* to *c*? Briefly justify your answers. (5')

Question 3: In the same circuit-switched network described above in problem 2, assume that applications transmit and receive at 200 Kbps. What is the maximum throughput between any two hosts? Briefly justify your answer. (5')

- **Exercise 105.** Imagine a Web-based weather system where <http://www.chetempofa.ch/lugano> shows the weather for Lugano. For each city, the system shows a page with the current temperature and weather conditions, plus a satellite image of the area. The temperature readings are updated every 2 minutes, while the satellite image is updated every 30 minutes.

Question 1: Write the *first* HTTP 1.1 conversation between a client and the server to access the Lugano page. Assume that both client and server support persistent connections. Clearly write all the requests and replies, but omit the content of the replies for binary objects (images). Clearly specify all the headers that control the properties of the connection as well as the caching policies and parameters. (10')

Question 2: Write a second HTTP 1.1 conversation (requests and replies) by the same client. Assume that this second request occurs three minutes after the first one. Explain how each object is handled with respect to caching. (10')

- **Exercise 106.** Answer the following questions about electronic mail.

Question 1: What is the difference between MAIL FROM: in SMTP and the From: header in the mail message? (5')

Question 2: What is the purpose of the Received: header? Which component(s) of the mail systems produces the Received: header? (5')

Question 3: What is a *mail relay server*? Explain the term with an example. (5')

- **Exercise 107.** You compose the following message for *joe@usi.ch* with a blind carbon copy to *bob@usilu.net*.

From:	ciccio@mail.ch
Subject:	meeting
To:	joe@usi.ch
Bcc:	bob@usilu.net
I'll see you tomorrow at 3PM.	
Ciccio	

The MX (DNS) record for both *usi.ch* and *usilu.net* points to *mgl.ti-edu.ch*. Write the full SMTP conversation between your user agent and the server at *mgl.ti-edu.ch*. (10')

- **Exercise 108.** Consider a sender *S* and a receiver *R* connected by link with throughput $T = 1\text{MB/s}$ and latency $L = 60\text{ms}$. Sender and receiver use the *Go-Back-N* protocol with a segment size of 8000B and a window size $W = 20$. How long does it take to transfer a file of $S = 80000\text{B}$ in case the link drops exactly every fourth packet in both directions? Justify your answer by writing the complete exchange between sender and receiver. (20')

- **Exercise 109.** A Web browser from address 100.200.12.34 connects to a Web server at address 30.40.50.60 and requests object <http://server.com/xyz>, which can not be found on the server. Write *all* the TCP packets of this connection. For each packet, specify the values of all the important headers. Fill all the unspecified headers with reasonable values. (20')

- **Exercise 110.** A network link has a throughput $T = 2\text{MB/s}$ and a latency $L = 2\text{ms}$. Suppose this link is used with a *stop-and-wait* protocol.

Question 1: What is the minimal segment size *S* that, in the absence of errors, would guarantee a link utilization of 50% or more? What is the effective throughput in this case? Justify your answers. (5')

Question 2: Using the same segment size S , what is the effective throughput in the presence of an error probability $p_e = 0.25$ (i.e., one in four packets gets lost)? Justify your answer. (5')

► **Exercise 111.** The TCP protocol is designed to adjust itself to links of varying latency. Explain how TCP does that. Explain what parameters of the protocols are relevant and how they are dynamically adjusted. Illustrate this process with an example. (10')

► **Exercise 112.** A router x issues the following *link-state advertisement* $LSA_x = \{(d, 1), (f, 1), (a, 2)\}$ and receives the following other advertisements, where letters (a, b, c, \dots) represent router addresses.

$LSA_a = \{(x, 2), (f, 1), (c, 3), (e, 2)\}$

$LSA_b = \{(g, 2), (c, 1), (e, 5)\}$

$LSA_c = \{(e, 1), (a, 3), (f, 2), (g, 4), (b, 1)\}$

$LSA_d = \{(g, 1), (f, 2), (x, 1)\}$

$LSA_e = \{(a, 2), (b, 5), (c, 1)\}$

$LSA_f = \{(d, 2), (x, 1), (a, 1), (c, 2)\}$

$LSA_g = \{(b, 2), (c, 4), (d, 1)\}$

Write the forwarding table of router x . Justify your answer by explaining briefly how link-state routing works and by illustrating a few steps of the Dijkstra algorithm. (25')

► **Exercise 113.** Answer the following questions.

Question 1: Do IPv4 headers and IPv6 headers have any fields in common? If any, describe the function of the common fields? (10')

Question 2: Do TCP headers and UDP headers have any fields in common? If any, describe the function of the common fields? (10')

► **Exercise 114.** Consider the following forwarding table

<i>network</i>	<i>port</i>
64.0.0.0/8	3
192.0.0.0/2	1
98.7.0.0/16	2
128.0.0.0/12	2
208.0.0.0/10	3
130.0.0.0/6	3
128.138.0.0/16	4
0.0.0.0/0	4

For each of the following destination addresses write the output port.

<i>address</i>	<i>port</i>
128.208.31.5	
75.21.40.22	
220.138.152.10	
130.21.86.66	
6.21.86.66	
34.60.120.159	
96.100.1.242	
128.138.241.69	
75.128.40.22	
208.71.49.43	

► **Exercise 115.** Consider a router with eight input ports, each one with a maximum throughput of 200000 packets per second, and eight output ports, four with a throughput of 240000 packets per second, and four with a throughput of 100000 packets per second. The switch fabric of the router has a throughput of 1.5 million packets per second. (10')

Question 1: Assuming that traffic spreads uniformly across input/output ports, is the router congested under a total input traffic of 1.4 million packets per second? If so, which queues are full at steady state? Briefly justify your answer. (5')

Question 2: Describe the behavior of the router under its maximum input traffic, with all its input ports running at maximum throughput. Is the router congested? If so, which queues are full at steady state? Briefly justify your answer. (5')

Question 3: Consider once again the behavior of the router under its maximum input traffic, and again assume that traffic spreads uniformly across input/output ports. Let d be the packet-drop rate (i.e., the number of packets dropped by the router per time unit). Assuming that every packet queue has a capacity of 1000 packets, and that all queues are empty at time $t = 0$, plot d as a function of time. Justify the result. (10')

► **Exercise 116.** A TCP segment with sequence number 3001 carries the following SMTP command:

MAIL FROM: <dude@elduderino.org>

What is the sequence number of the next TCP segment going from the client to the server? Can you also determine the sequence number of the next TCP segment going from the server to the client? If so, what is that sequence number? Briefly justify your answers. (10')

► **Exercise 117.** For each one of the following subnet addresses, give an example of an IP address that can be assigned to that subnet, and one that can not.

<i>subnet</i>	<i>IP address in subnet</i>	<i>IP address outside subnet</i>
192.0.0.0/4		
230.208.32.0/28		
88.68.124.132/30		
103.124.20.128/26		
128.129.0.0/16		
128.131.64.0/18		
53.220.211.0/24		
100.0.0.0/6		
203.242.138.0/18		
184.180.0.0/12		

Also, do any of these network addresses overlap? If so, which ones? (10')

► **Exercise 118.** Consider the following network where routers use a distance-vector routing protocol.

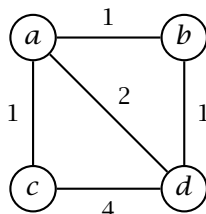

Assuming that routers exchange routing information synchronously (at the same time), illustrate the state of each router until the routing protocol stabilizes. (25')

- **Exercise 119.** Consider the server of a mailing list called *studentparties@lists.unisi.ch*. Suppose *joe@unisi.ch*, *mario@unisi.ch*, and *pippo@mail.ch* are subscribed to the list, and that *bart@blabla.com* sends the following message to the list:

From: bart@blabla.com
To: studentparties@lists.unisi.ch

Let's all go to the beach today!
 See you there,
 Bart

Write *all* SMTP interactions necessary to send and deliver the message, between Bart's user agent and the list server, and then between the list server and all the mail servers of the subscribers. For simplicity, you may assume that server responses are always positive, and therefore you may ignore them. (20')

- **Exercise 120.** Explain the difference between routing and forwarding. (10')
- **Exercise 121.** Describe the circumstances in which a router drops packets at output ports. Give an example in which this situation can occur, specifying the traffic conditions as well as maximum throughput of each component of the router. (10')
- **Exercise 122.** Describe the connection-setup phase of TCP. Describe each packet sent by client and server highlighting the relevant headers, the information they carry, and how it relates to the state of the connection maintained by client and server. Give three examples: one where the connection phase is completed successfully, one where the connection is refused, and one where the connection times out. (20')
- **Exercise 123.** Consider a *stop-and-wait* reliable transport protocol. Specify a variant of this protocol in which the receiver sends a second (repeated) acknowledgement, after having received and immediately acknowledged a data segment, if it does not receive another data segment within 100ms. Write the finite-state machine that specifies the receiver. Also argue whether this receiver behavior can help to reduce transmission time. Support your argument by drawing one or more diagrams of a example session between a sender and a receiver. (*Hint:* the diagrams show the exchange of data along two vertical time lines representing the sender and receiver, respectively.) (30')
- **Exercise 124.** Consider the following network where routers use a distance-vector routing protocol.

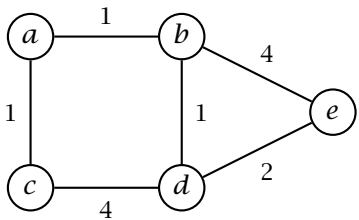

Write the routing information transmitted by every router until the protocol stabilizes. Assume that routers exchange routing information synchronously once per second. Therefore, identify each message with a progressive time-stamp (1, 2, ...), a source, and one or more destinations. (30')

- **Exercise 125.** Three important properties of a communication channel are cost of setup and maintenance, ability to share the channel among multiple senders/receivers, and quality of service. Compare and contrast circuit switching and packet switching especially with regard to these three factors. (10')
- **Exercise 126.** A web server is serving requests for the *www.speedopizza.com* web site. The site consists of a single page containing the logo of the restaurant and the names and images of 4 types of pizza. The web site is implemented with static files placed in a given directory. This is the content of this directory:

```

-r--r--r-- apache apache 4123 2009-04-24 14:01 index.html
-r--r--r-- apache apache 214123 2009-04-24 14:01 logo.jpg
-r--r--r-- apache apache 70534 2009-04-24 14:01 porcini.jpg
-r--r--r-- apache apache 55912 2009-04-24 14:01 sicilia.jpg
-r--r--r-- apache apache 65109 2009-04-24 14:01 peperoni.jpg
-r--r--r-- apache apache 94388 2009-04-24 14:01 diavola.jpg

```

Question 1: Write the HTTP replies corresponding to the following requests received by the web server. Be as specific as you can, including, the appropriate headers. If the reply has a body, then just write the single line "...BODY..." (10')

```

HEAD /index.html HTTP/1.1
Host: www.speedopizza.com
Connection: close

```

```

GET /logo.jpg HTTP/1.1
Host: www.speedopizza.com
Connection: close

```

```

GET /porcini.jpg HTTP/1.1
Host: www.speedopizza.com
Connection: close
If-Modified-Since: Mon, 27 Apr 2009 12:01:00 GMT

```

```

GET /napoli.jpg HTTP/1.1
Host: www.speedopizza.com
Connection: close
If-Modified-Since: Mon, 12 Jan 2009 14:28:24 GMT

```

Question 2: The restaurant offers a special *pizza of the day* that is advertised on the web site. However, the owner of the restaurant notices that some of the customers ask for the *pizza of the day* that was offered two days ago, even though he has updated the web page since then. Briefly explain what could cause the problem and suggest how the problem could be solved by configuring the server to send an appropriate HTTP header with the index page. (5')

► **Exercise 127.** The schematic diagram below shows three clients C_1 , C_2 and C_3 connected to the Internet through a 15Mbits/s access link. Using HTTP, clients fetch objects of average size of 900,000 bits, at a total rate of 10 requests per second (for all three clients). Suppose that the amount of time that it takes from when the router R_2 forwards an HTTP request until it receives the response (*Internet delay*) is 2 seconds on average. Model the total average response time as the sum of the *Internet delay* and the average *access delay*, which is the delay between R_2 and R_1 . For the average access delay use the formula $\Delta/(1 - \Delta\beta)$, where Δ is the average time required to send an object over the access link and β is the arrival rate of objects to the access link. (Is this formula dimensionally correct?)

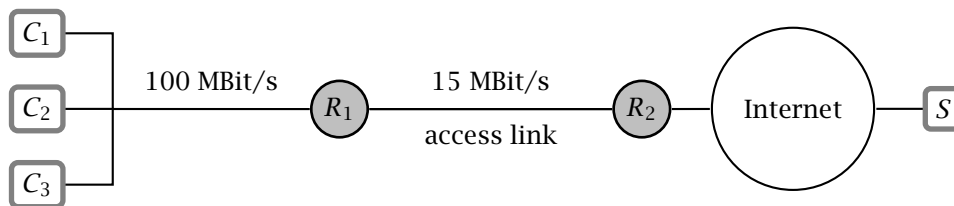

Question 1: Find the total average response time. Briefly justify your answer. (10')

Question 2: Now suppose a cache is installed in the same local network with the clients. assuming that the hit rate is 60%, find the total response time. Briefly justify your answer. (5')

Question 3: Explain the meaning of the formula $\Delta/(1 - \Delta\beta)$ that computes the average transmission delay of multiple objects arriving at a constant rate at the same link. The throughput of the link is T (bits/second), the average size of the objects is S (bits), $\Delta = S/T$, and the objects arrive at a rate β (objects per second). (10')

► **Exercise 128.** Answer the following questions about Internet electronic mail.

Question 1: You send an e-mail to *name@eecs.berkeley.edu*. How does your mail user agent (or your mail transport server) find the IP address of the mail server responsible for these mailboxes? (5')

Question 2: What is *MIME* and how is it used to extend Internet mail? Write an example message detailing the relevant headers and the relevant content fragments. (10')

► **Exercise 129.** Compare and contrast the *Selective Repeat* and *Go-Back-N* protocols. Describe the advantage of *Selective Repeat* with an example. (10')

► **Exercise 130.** An implementation of the *Selective Repeat* protocol uses sequence-numbers from 1 to 4 (i.e., the packets are numbered 1 → 2 → 3 → 4 → 1 → 2...). The window size, on both the sender and the receiver, is set to 3. The underlying network is unreliable and packets might get lost or delivered out of order, but a checksum guarantees that their content is error-free.

Question 1: This setting is problematic because in some cases the receiver can not decide whether a packet is new or it is a retransmission of a previous packet. Show a scenario that illustrates this problem. Use arrows to represent packets and label them with their sequence numbers. (10')

Question 2: How can you correct this problem with a minimal change in the code? (5')

► **Exercise 131.** *A* and *B* are communicating over a TCP connection. *B* sends a packet with ACK number 490, which is received by *A*. Suppose *A* then sends two segments to *B*, one immediately after the other. The first and second segments contain 50 and 70 bytes of data, respectively. In the first segment, the source port number is 1028 and the destination port number is 21. *B* sends an ACK after receiving each packet.

Question 1: What are the sequence number, source port, and destination port of the second segments sent from *A* to *B*? Briefly justify your answer. (5')

Question 2: Assume the first segment arrives before the second segment, so *B* sends an acknowledgment after each segments it receives. What is the sequence number in each acknowledgment? Briefly justify your answer. (5')

► **Exercise 132.** Host *A* is sending a file to Host *B* over a TCP connection. The diagram below plots the size of the congestion window over time, in the presence of events labeled 1 through 6.

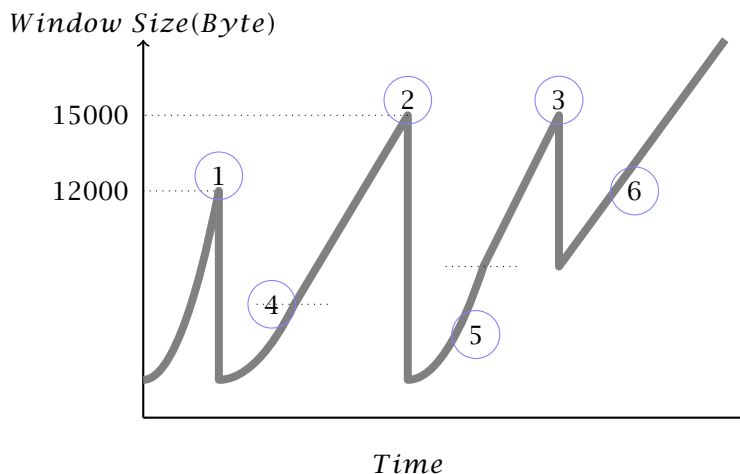

Question 1: What is the state of the TCP state machine at host *A* when events 1, 2, and 3 occur? (5')

Question 2: What is the window size of the sender at event 4? (5')

Question 3: Briefly explain the behavior of TCP during events 5 and 6, and also the purpose of those behaviors. (10')

► **Exercise 133.** Answer the following questions on IP addressing.

Question 1: Write the number of IPv4 addresses in each of the following network addresses. Briefly justify your answers explaining the meaning of the prefix notation.

- 142.11.240.0/22
- 127.0.0.0/8
- 192.168.0.0/16
- 128.138.242.0/24
- 0.0.0.0/0

(5')

Question 2: Explain the concept of *supernetting* giving an example in which three subnet addresses are combined.

(5')

► **Exercise 134.** Answer the following questions on forwarding.

Question 1: An IPv4 router has 16 physical interfaces, which function as both input and output interfaces. The network in which the router lives has a total of N addresses. Considering the forwarding table as a mathematical function, write the domain and range of the forwarding function. At most, how many entries does the forwarding table contain? How many addresses does the router use? Briefly justify your answers.

(10')

Question 2: Does a router in a virtual-circuit network have a forwarding table? If so, how is that different from the forwarding table in a datagram network? Briefly justify your answers writing also the domain and range of the forwarding function in a virtual-circuit network.

(10')

► **Exercise 135.** Answer the following questions on routing.

Question 1: Briefly explain, using an example, the notion of *hierarchical routing*, and how that is realized in today's Internet. In particular, explain the role of inter-domain and intra-domain routing and explain how each contributes to building the forwarding tables.

(10')

Question 2: A router has 5 input interfaces and 5 output interfaces, each with the same throughput x . The router also has a switch fabric operating at maximum throughput y .

- a. Are there values of x and y for which the router can operate without input queues? If not, explain why. If so, explain how.
- b. Are there values of x and y for which the router can operate without output queues? If not, explain why. If so, explain how.
- c. Are there values of x and y for which the router can operate without input and output queues? If not, explain why. If so, explain how.

(10')

► **Exercise 136.** Consider the following network. Link costs are 1 except where otherwise indicated. Use Dijkstra's algorithm to compute the forwarding table of router g . Write the result in the first table below. Also, show the state of the algorithm at every step using the second table below and if necessary in the next page. (*Hint:* the state of the algorithm consists of a "distance" vector and a "previous" vector, so for each destination and each step, write the distance followed by the previous.)

(30')

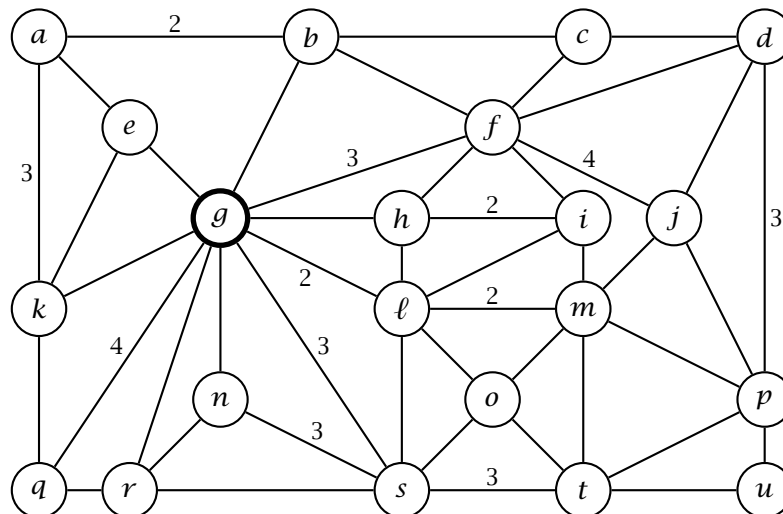

Forwarding Table

<i>a</i>	<i>b</i>	<i>c</i>	<i>d</i>	<i>e</i>	<i>f</i>	<i>g</i>	<i>h</i>	<i>i</i>	<i>j</i>	<i>k</i>	<i>ℓ</i>	<i>m</i>	<i>n</i>	<i>o</i>	<i>p</i>	<i>q</i>	<i>r</i>	<i>s</i>	<i>t</i>	<i>u</i>	

Execution of Dijkstra's Algorithm

step	<i>a</i>	<i>b</i>	<i>c</i>	<i>d</i>	<i>e</i>	<i>f</i>	<i>g</i>	<i>h</i>	<i>i</i>	<i>j</i>	<i>k</i>	<i>ℓ</i>	<i>m</i>	<i>n</i>	<i>o</i>	<i>p</i>	<i>q</i>	<i>r</i>	<i>s</i>	<i>t</i>	<i>u</i>	
1																						
...

step	<i>a</i>	<i>b</i>	<i>c</i>	<i>d</i>	<i>e</i>	<i>f</i>	<i>g</i>	<i>h</i>	<i>i</i>	<i>j</i>	<i>k</i>	<i>ℓ</i>	<i>m</i>	<i>n</i>	<i>o</i>	<i>p</i>	<i>q</i>	<i>r</i>	<i>s</i>	<i>t</i>	<i>u</i>	
1																						
...

► **Exercise 137.** Consider the following network path from *a* to *d*, where each link has the noted MTU. Router *a* sends an IPv4 packet to *d* containing a UDP datagram with 4000 bytes of payload. The packet is fragmented along the way. Write all the fragments received by *d*, specifying the relevant fragmentation information. (20')

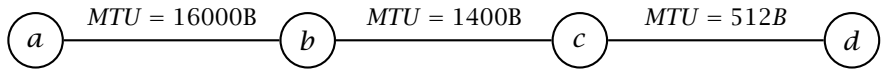

► **Exercise 138.** Consider the following network path from *a* to *d*, where each link has the noted maximum throughput *T* and latency *L*. Suppose host *a* runs a Web browser that accesses, through HTTP, a document on server *d*. The document consists of 4 objects of 1000B, 5000B, 6000B, and 100KB, respectively.

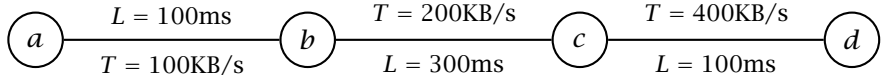

Question 1: How long does it take for the browser to receive all the web objects with and without pipelining? Ignore the behavior of the underlying TCP connection, so assume that each host can send packets back-to-back, and that they are all received correctly and in order. Justify your answers. (10')

Question 2: Now assume that host *b* runs a (transparent) caching proxy. What is the total delivery time if only the first object is in cache? What is the total delivery time if only the second object is in the cache? What is the total delivery time if only the fourth object is in the cache? Justify your answers. (10')

► **Exercise 139.** Hosts *A*, *B*, and *C* are connected to the Internet through asymmetric access links. The following table lists the maximum upload and download rates for the three hosts.

host	max upload	max download
<i>A</i>	100KB/s	500KB/s
<i>B</i>	50KB/s	100KB/s
<i>C</i>	60KB/s	400KB/s

Assume that the core of the network does not further reduce transfer rates, and does not introduce significant latencies. What is the best way to transfer a 500MB file from host *A* to hosts *B* and *C* so as to minimize each of their respective transfer time? What are the transfer times in this case? How low can *B*'s upload rate be without incurring any increase in transfer time? What are the transfer times if *B*'s upload rate is reduced to 30KB/s? What if *B*'s upload rate remains at 50KB/s, but its download rate is reduced to 80KB/s? Answer each question in turn. Briefly justify your answers. (20')

► **Exercise 140.** Explain the longest-prefix matching algorithm used in Internet forwarding. Explain how it works and why forwarding is carried out that way. Show an example in which address ranges are assigned to subnets in a non-trivial way, in particular in a way that justifies longest-prefix matching. With this assignment, show a few examples of how addresses in the various ranges are forwarded. (20')

► **Exercise 141.** You are sending an e-mail message to *friend@someschool.edu*. Describe every step, including DNS and SMTP, of the process undertaken by either your user agent or your mail server to deliver the message to the mail server of the recipient. Assume the address is valid and that no communication or server errors occur. (20')

► **Exercise 142.** Consider an HTTP 1.0 connection from a user agent to a server to retrieve a 4Kb object called *index.html*.

Question 1: Write the HTTP request and a successful reply (omitting the content of the reply). (5')

Question 2: Write all the TCP segments exchanged for the HTTP request and reply. Assume an MTU of 1400 bytes. For each segment, write all the relevant information, including port numbers, sequence number, ack number, flags, size, etc. (15')

► **Exercise 143.** Consider the following network where routers use a distance-vector routing protocol.

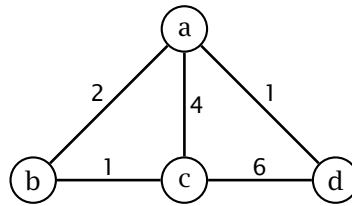

Assume that all routers start at time 0, that routing messages are sent periodically every 10 seconds. Assume also that links have a fixed latency of 1 second. Write the iterations of the distance-vector routing algorithm, at times 0, 10, ..., until the protocol converges to a stable state. For each iteration, specify the time and list the routing tables of each router. (20')

► **Exercise 144.** How and why does TCP estimate the network-level round-trip time for its connection? How is the estimated round-trip time used in the protocol? Describe and explain the estimation algorithm using an example. Also, discuss the goal of this algorithm, showing again by example what would happen if the round-trip time is underestimated or overestimated. (20')

► **Exercise 145.** A file of size $S = 1\text{GB}$ ($1\text{GB} = 10^9\text{B}$) available from host a is downloaded by n hosts, b_1, b_2, \dots, b_n . Host a has a maximum upload (output) throughput $U_a = 2\text{MB/s}$ and a maximum download (input) throughput $D_a = 1\text{MB/s}$. Hosts b_1 through b_n each have a maximum upload (output) throughput $U_b = 100\text{KB/s}$ and a maximum download (input) throughput $D_b = 500\text{KB/s}$. All receiver hosts start their download at the same time $t = 0$ and the download finishes at time T when all hosts b_1, b_2, \dots, b_n have obtained a copy of the entire file.

Question 1: What is the best total download time T_{cs} achievable with a “client-server” protocol with $n = 10$ receivers? Show and briefly justify your calculations. (10')

Question 2: What is the best total download time T_{p2p} achievable with a “peer-to-peer” protocol with $n = 10$ receivers? Show and briefly justify your calculations. (10')

Question 3: What is largest number of receivers n for which a client-server protocol is not worse than a peer-to-peer protocol? Show and briefly justify your calculations. (10')

► **Exercise 146.** Consider the following HTTP request and the corresponding reply:

```

PUT /some/file/called/blah HTTP/1.0
Host: www.example.edu
Content-Type: text/plain
Content-Length: 1000

blah blah blah...

-----
HTTP/1.0 405 Method Not Allowed
Content-Length: 400
Content-Type: text/html
Connection: close

<html><head>
<title>Error: Method Not Allowed</title>
</head><body>...
  
```

This request and reply are sent over a TCP connection between client c on port 1234 and server s on port 80. Write every TCP packet sent over this connection, including those for the opening and closing of the connection. For each packet, write (1) the source address (c or s), (2) the destination address (c or s), (3) the source port, (4) the destination port, (5) the sequence number, (6) the acknowledgment number, (7) the main flags (ACK, SYN, FIN), and (8) the first few bytes of its data (if any). Assume a maximum packet size of 1500 bytes, which means that each TCP packet can carry at most 1440 bytes of data. Use the template below to write each packet. (30')

<i>src IP</i>	<i>dst IP</i>	<i>src port</i>	<i>dst port</i>	<i>seq. number</i>	<i>ack. number</i>	<i>flags</i>
<i>content:</i>						

► **Exercise 147.** You send an e-mail message to your friend *amir@amici.ch* with a copy to your other friend *marco@amici.ch*, and with a “blind” carbon copy to *antonio@usi.ch*. The subject of the message is “Pizza,” and the text of the message is “Let’s go out for a pizza tonight.” Assuming your e-mail address is *student@usi.ch* and that your mail user-agent is configured to use the mail server *mail.usi.ch*, write the complete SMTP exchange between your user agent and the mail server, including the whole body of the message. (10')

► **Exercise 148.** A sender transfers a 200 MB file to a receiver using a “stop-and-wait” reliable transport protocol with a maximum segment size of 4 KB and timeout of $\Delta = 500$ ms, through a network link with latency $L = 40$ ms and throughput $T = 200$ KB/s.

Question 1: How long does the transfer take in the absence of errors or losses in the network? Show and briefly justify your calculations. (10')

Question 2: What is the expected transfer time in case the network loses on average one out of 1000 packets? Show and briefly justify your calculations. (10')

► **Exercise 149.** Answer the following questions. (10')

Question 1: Does UDP provide any support for reliability? If so, in what way and through which header fields?

Question 2: Does TCP provide any support for reliability? If so, in what way and through which header fields?

Question 3: What is the effect of the header *Connection: close* in an HTTP request?

Question 4: Compare packet switching and circuit switching in terms of the efficiency in the usage of network links? Which one is better? Why?

► **Exercise 150.** Your computer uses a DNS resolver connected through a local-area network with latency $L_l = 1$ ms. The DNS resolver is connected to the Internet through an access link with $L_h = 50$ ms. Assuming no other latencies in the whole network, and considering that DNS packets have negligible sizes, how long does it take for your computer to resolve the address *www.chomsky.info*. Assume also that neither the requested name nor its domain are in the DNS cache (local or remote). Show and briefly justify your calculations. In particular, list all the packets sent and received by your local resolver. (20')

► **Exercise 151.** A user accesses a Web document consisting of a 10KB HTML page plus a 100 KB image and a 10MB video clip, all stored at their origin server S . The user’s browser C is configured to access the Web through a caching proxy P . The connection between the browser and the proxy has latency $L_{CP} = 1$ ms and throughput $T_{CP} = 1$ MB/s. The connection between the proxy and the origin server has latency $L_{PS} = 100$ ms and throughput $T_{PS} = 100$ KB/s. (20')

Question 1: What is the total transfer time when the image is already in cache? Show and justify your calculations.

Question 2: What is the total transfer time when the video clip is in cache? Show and justify your calculations.

► **Exercise 152.** An application running on host A opens a TCP connection with an application running on host B , and immediately starts transferring a large file. The latency between A and B is $L = 200\text{ms}$, the maximum throughput between A and B is $T = 500\text{KB/s}$, and the maximum segment size is $MSS = 1000\text{B}$. The receiver has plenty of capacity, and therefore you should assume that the receiver window is always larger than the congestion window.

Question 1: How long does it take for the TCP connection to reach the maximum throughput? Justify your answer by showing and briefly describing your calculation. (*Hint:* recall that, in the initial “slow-start” phase, the sender opens the congestion window exponentially, increasing its size by one segment for each acknowledged segment. Remember also to consider the initial handshake.) (10')

Question 2: Assume that a packet is dropped only when the sender rate goes over the maximum throughput T . Also assume that only sender segments are dropped, and therefore that acknowledgments are always received correctly. In this case, what is the effective throughput of the TCP connection over a long period of time? Justify your answer by showing and briefly describing your calculation. (*Hint:* show the throughput controlled by TCP over time; model the network as a kind of conveyor belt whose *capacity*—the maximum amount of data it can contain at any given time—determines the maximum amount of data that can be sent without losses.) (10')

► **Exercise 153.** A router with two interfaces is configured with the following forwarding table:

network address	interface
24.36.0.0/16	1
138.128.0.0/16	2
125.200.192.0/18	2
31.0.0.0/8	1
138.89.0.0/16	2
31.98.7.0/24	2
138.128.10.0/24	2
31.80.66.0/24	2
0.0.0.0/0	1
125.200.128.0/18	2
125.201.0.0/16	2
31.99.0.0/16	2

Question 1: Where would the router forward a datagram addressed to 31.99.100.101? Justify your answer by describing at a high-level forwarding algorithm used in IP routers. (10')

Question 2: Can the router compress its forwarding tables? (I.e., reduce the number of table entries.) If so, show the minimal set of entries that are exactly equivalent to the given table. (10')

► **Exercise 154.** Consider the network shown below in which routers use a distance-vector routing algorithm.

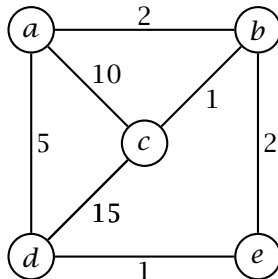

In the initial state each router knows the costs of the links to its neighbors. Assuming that routers exchange distance vectors in a synchronous way (i.e., all at the same time) show the state of router a after each update to its routing tables until the protocol converges. (20')

► **Exercise 155.** A router has three input ports, a switch fabric capable of sustaining a maximum throughput of 9000 packets per second, and a number of output ports each capable of sending 9000 packets per second. Each input port has a queue of size q , and starts with an empty queue at time 0. The three input ports receive the traffic described by the three graphs below, respectively.

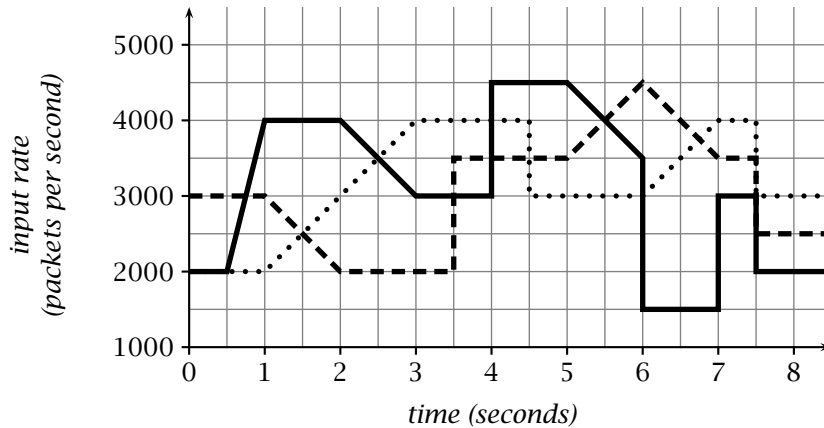

Assume that the switch fabric processes packets in a round-robin fashion (i.e., one packet from each input port in turn; if no packets are available from one port, the switch fabric skips to the next port, and so on). What is the minimum queue size \bar{q} that would allow the router to process all input packets? Assuming that $q = \bar{q}/2$, at what time does the router drop the first packet? Justify your answers by showing and briefly explaining your calculations. (20')

► **Exercise 156.** Answer the following questions.

Question 1: Explain how IPv4 fragmentation works using an example in which a datagram is split up in at least three fragments. (5')

Question 2: Describe the IPv6 datagram format. Discuss at least two headers other than the version and the source and destination address, explaining their purpose. (5')

Question 3: Explain how TCP closes a connection. Draw a diagram of the various segments sent by the two sides. Explain what happens if any segment is lost. (5')

Question 4: Describe at a high level a symmetric encryption scheme to protect the privacy of a message m sent by sender S to receiver R . Also explain briefly what it means for this scheme to be perfectly secure. (5')

► **Exercise 157.** Consider a reliable connection between a sender and a receiver implemented with a Go-Back-N protocol with maximum segment size $MSS = 2\text{KB}$ and with a fixed window size $W = 8$. The network latency between the sender and receiver is $L = 200\text{ms}$, the access link of the sender allows a maximum transmission throughput $T_S = 100\text{KB/s}$, and both sender and receiver have very high reception throughput.

Question 1: How long does it take to reliably transmit a file of size $S = 100\text{KB}$ in the best case, without any loss of packets? Justify your answer. (10')

Question 2: Assuming the timeout is set to 1s, how long does it take to reliably transmit the same file ($S = 100\text{KB}$) in the presence of losses when one out of 20 packets gets lost in both directions? Justify your answer. (10')

► **Exercise 158.** A router has 16 input interfaces capable of receiving up to 10000 packets per second, and 16 output interfaces capable of sending 20000 packets per second.

Question 1: Let T_S be the maximum throughput of the switch fabric. What is the maximum (total, best-case) throughput of the router? In particular, are there values of T_S for which the total throughput does not depend on T_S ? Justify your answers. (10')

Question 2: Consider the previous question in the case of a specific distribution of traffic. Let T_S be the maximum throughput of the switch fabric, and suppose that 20% of the input traffic goes to output interface 1, 10% to output interface 2, and the rest is distributed uniformly onto all other interfaces. What is the maximum throughput of the router in this case? Also, for what values of T_S (if any) does the router drop packets on its input and output queues, respectively? Are there any values of T_S for which neither queues would ever be full? Justify your answers. (10')

► **Exercise 159.** An HTTP connection is carried by a TCP connection with maximum segment size of 1400 bytes.

Question 1: Within this connection, a TCP segment with sequence number 3344 carries the following HTTP request:

```
HTTP/1.0 404 Not Found
Content-Type: text/html
Content-Length: 41
```

```
<html><body>Page Not Found!</body></html>
```

What is the sequence number of the next segment going from the Web server to the client? Justify your answer. (Remember that all HTTP header lines end with a CRLF sequence.) (10')

Question 2: Within the same connection, a TCP segment with sequence number 6677 carries the following HTTP request:

```
HTTP/1.0 200 Ok
Content-Type: image/jpeg
Content-Length: 25000
```

a binary image...

What is the sequence number of the next segment sent by the server in this case? Justify your answer. (10')

► **Exercise 160.** Antonio (*antonio@usi.ch*) sends a message to a mailing list dedicated to teaching and related discussions. The list is served by *lists.org*. Thus, the destination of the message is *teachers@lists.org*, and the subject line is “retake exam.” Among the subscribers is Cyrus (*cyrus@usi.ch*) who will therefore receive a copy of Antonio’s message. Describe exactly what happens in terms of application-level protocols for each of these two message exchanges, starting from the necessary DNS queries, and then proceeding with the SMTP sessions. Simply describe the DNS requests and replies without detailing the DNS resolution processes. Then show the entire SMTP session for each exchange. You may skip the server replies in the SMTP sessions, but make sure you clearly specify the relevant information, including the sending server, the receiving server, the envelope destination and sender, and the message destination and sender. (30')

► **Exercise 161.** Describe an IPv6 datagram containing a TCP segment. Describe both the IP and TCP headers. Describe as many header fields as you can remember. For each field, briefly describe the purpose of the field and the allowable values. (10')

► **Exercise 162.** Router x issues the *link-state advertisement* $LSA_x = \{(g, 1), (f, 3), (a, 2), (e, 4), (b, 1)\}$ and receives the following other advertisements, where letters (a, b, c, \dots) represent router addresses.

$LSA_a = \{(d, 2), (c, 1), (f, 1), (x, 2)\}$

$LSA_b = \{(e, 2), (x, 1), (g, 5)\}$

$LSA_c = \{(d, 1), (a, 1), (f, 2)\}$

$LSA_d = \{(e, 1), (a, 2), (x, 1)\}$

$LSA_e = \{(b, 2), (x, 4), (d, 1)\}$

$LSA_f = \{(c, 2), (a, 1), (x, 3), (g, 2)\}$

$LSA_g = \{(f, 2), (b, 5), (x, 1)\}$

Write the forwarding table of router x . Identify the output interfaces with the corresponding neighbor router. Justify your answer by explaining briefly how link-state routing works. (20')

► **Exercise 163.** A mailing-list server called *lists.inf.usi.ch* receives the following message posted to the *jokes* list:

From: Antonio Carzaniga <antonio.carzaniga@usi.ch>
Subject: a good one by Yogi Berra
To: Jokes Mailing List <jokes@lists.inf.usi.ch>

You can observe a lot by just watching.

The *jokes* list has four subscribers: *koorosh@usi.ch*, *amir@usi.ch*, *gino@colorado.edu*, and *antonio.carzaniga@usi.ch*. Write all the SMTP sessions that the server uses to distribute the message to the members of the list. Do not worry about remembering the exact numeric codes sent by the receiving server, but be precise in listing *everything* the sender writes in each session. Assume all sessions are successful and without errors. (20')

► **Exercise 164.** You open your web browser and go to the url *http://www.usi.ch/slogan.jpg*. Your browser then fetches and displays the page (an image). Write every network packet that your computer sends and receives to accomplish this task. For each packet, write the important transport-level headers as well as the relevant application-level content (abbreviate the content of the image with "..."). The important transport-level headers are the port numbers (for both TCP and UDP) and sequence and acknowledgment numbers, and flags (for TCP). For example, for an HTTP request, write the TCP headers as well as the HTTP request. Assume the maximal transmission unit of your network is 1500 bytes, and the size of the *slogan.jpg* image is 4000 bytes. (20')

► **Exercise 165.** Twenty users download a large file through a peer-to-peer system. The size of the file is 2GB. The whole file is available from two other "seed" users S_1 and S_2 connected to the network with an access links of maximal upload rates $U_1 = 200\text{KB/s}$ and $U_2 = 500\text{KB/s}$, respectively. Of the 20 users, 5 have a "fast" access link and 15 have a slow access link. A "fast" access links has maximal upload and download rates of $U_{fast} = 100\text{KB/s}$ and $D_{fast} = 500\text{KB/s}$, respectively. A "slow" access links has maximal upload and download rates of $U_{slow} = 50\text{KB/s}$ and $D_{slow} = 200\text{KB/s}$, respectively. What is the (theoretical) best total download time? This is the time it takes for all twenty users to obtain the whole file. Justify your answer by showing and briefly explaining your calculations. (For simplicity, let 1GB and 1Kb represent 10^9 and 10^3 bytes, respectively.) (20')

► **Exercise 166.** A sender sends a file to a receiver using TCP. The sender application simply connects to the receiver and sends the file as fast as the TCP connection permits, and then closes the connection; the receiver accepts the connection, reads from it as fast as data comes in, and then closes the connection. The network between the sender and the receiver has a transmission delay $d = 500\text{ms}$, a maximum transmission rate $R = 200\text{KB/s}$, and a maximum segment size $MSS = 1\text{KB}$. The network introduces no transmission errors or packet losses when the transmission rate is less than R . Notice that R is the maximum rate of the entire path between sender and receiver. However, the sender may try to send at a higher rate, in which case those packets will be dropped by the network. More specifically, every packet that causes the instantaneous transmission rate to exceed R is dropped. (Hint: the instantaneous transmission rate induced by a packet p is the size of p divided by the time between the transmission of p and the transmission of the immediately preceding packet p' that was not itself dropped.)

Question 1: Exactly how long does it take for the sender (and receiver) to complete the transmission of an 80Kb file? (10')

Question 2: Does the network ever drop any packets in the transmission of the 80Kb file? If so, exactly when does that happen for the first time? If not, what is the minimum file size that would causes the network to drop a packet? Justify your answers by showing and briefly explaining your calculations. (10')

Question 3: What is the effective transmission rate of the TCP connection for a continuous stream of data? That is, the rate available to the application (as opposed to the network-level rate available at the transport layer) computed by excluding the initial "slow start" phase of the TCP transmission. Justify your answers by showing and briefly explaining your calculations. (10')

► **Exercise 167.** A user U connects to the Web through a caching proxy P . U goes to a Web page consisting of an HTML file *one.html*, size 20Kb, and two image files, *two.jpg* and *three.jpg*, sizes 100Kb and 80Kb, respectively, all of which are from the same origin server S and that are requested by U in the given order (one, two, three). The link between U and P has transmission delay $d_1 = 10\text{ms}$ and rate $R_1 = 1000\text{KB/s}$; the link between P and S has transmission delay $d_2 = 100\text{ms}$ and rate $R_2 = 100\text{KB/s}$. Suppose all three objects are in P 's cache, where they were retrieved at times T_1 , T_2 , and T_3 , respectively. Feel free to assume that requests are pipelined. In any case, state your assumptions explicitly.

Question 1: Write all HTTP requests and their corresponding replies involved in this interaction, indicating for each request/reply which is the client-side and which is the server-side. Assume in this case that the cached copies of *one.html* and *three.jpg* are valid, and instead *two.jpg* was modified after T_2 . Abbreviate the object content in the replies (if any) by writing "...". (10')

Question 2: Exactly how long does it take for the whole page to be transmitted to the user in the case described above in exercise 1? Justify your answers by showing and briefly explaining your calculations. (10')

Question 3: Exactly how long does it take for the whole page to be transmitted to the user in the case where the cached copies of *one.html* and *two.jpg* are valid, and instead *three.jpg* was modified after T_3 ? (10')

► **Exercise 168.** Compare and contrast distance-vector and link-state routing. List and briefly explain their differences. (10')

► **Exercise 169.** Consider the following network in which routers use distance-vector routing.

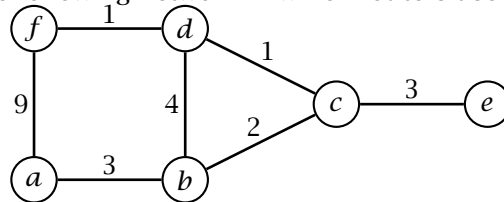

Question 1: Show the forwarding table of router *a* from the initialization until the state of the table converges. Assume that all routers initialize at the same time, and that, at each round of the algorithm, each router receives distance vectors from all its neighbors simultaneously. (20')

Question 2: After convergence, what happens if the cost of the link between *c* and *d* raises from 1 to 4? Again, show the evolution of the forwarding table of router *a*. (10')

► **Exercise 170.** Compare and contrast client/server (e.g., with HTTP) and peer-to-peer (e.g., with BitTorrent) file transfer. In particular, describe a situation in which peer-to-peer is better in terms of total transfer time. (10')

► **Exercise 171.** Compare and contrast IPv4 and IPv6. In particular, briefly describe the most important header fields in the two protocols. (10')

► **Exercise 172.** Consider two hosts *A* and *B* connected through a network as in the following diagram:

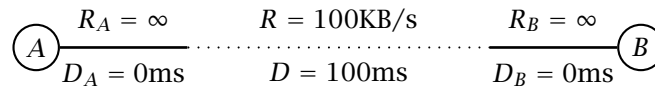

A and *B* are connected to the network with access links with infinite transmission rate and zero transmission delay. The network path that connects *A* and *B* has a maximum transmission rate $R = 100\text{KB/s}$, a total transmission delay $D = 100\text{ms}$, and maximum segment size $MSS = 1\text{KB}$. The network introduces no transmission errors or packet losses when the transmission rate computed over a period of D is less than R . Formally, every packet sent at time t_0 is successfully transmitted if and only if the average transmission rate of successfully transmitted packets in the interval between $t_0 - D$ and t_0 was more than R .

Question 1: How long does it take for *A* to transfer a 500KB file to *B* using the go-back-N protocol with a fixed window of $W = 10$ segments? Justify your answer. (10')

Question 2: How long does it take for *A* to transfer a 500KB file to *B* using the go-back-N protocol with a fixed window of $W = 20$ segments? Justify your answer. (10')

Question 3: How long does it take for *A* to transfer a 500KB file to *B* using TCP? Consider *all* packets transmitted by TCP. Justify your answer. (20')

► **Exercise 173.** Consider the network of autonomous systems depicted below.

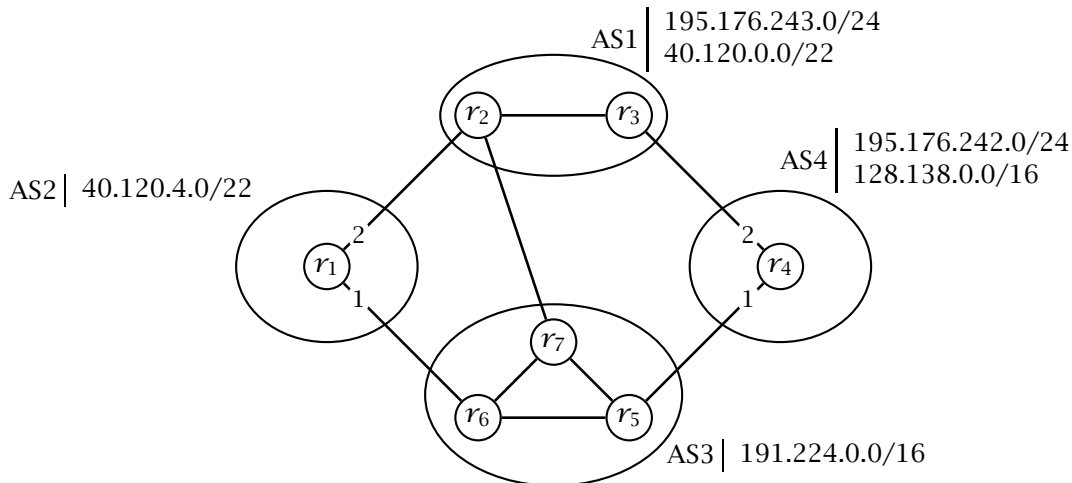

Question 1: Indicate (on the figure) which connections are eBGP and which ones are iBGP. (5')

Question 2: Assuming that every AS is willing to forward traffic of every other AS, write the forwarding table of routers r_1 and r_4 after the convergence of the protocol. You must also consider the supernetting feature of BGP. (Write the forwarding tables referring to the interface numbers given by the labels on the links of r_1 and r_4 .) (15')

► **Exercise 174.** A sender A sends a file to a receiver B using a stop-and-wait transport protocol over a link with maximum segment size $MSS = 1\text{KB}$, transmission rate $R = 1000\text{KB/s}$, and delay $D = 100\text{ms}$. The sender detects errors with a fixed timeout $T = 1\text{s}$. Acknowledgment packets can be considered to have zero length.

Question 1: How long would it take to transmit a 300KB file in the best case? Justify your answer. (5')

Question 2: What is the expected transmission time for a 300KB file when each packet is dropped with probability $p = 0.01$ (i.e., one every 100 packets is dropped)? Justify your answer. (15')

► **Exercise 175.** Consider a peer-to-peer system in which host A holds a 100MB file and three other hosts B_1 , B_2 , and B_3 want to obtain that file. The access link of A has a maximum upload speed of $U_A = 200\text{KB/s}$ while all other hosts have an access link with maximum upload and download speeds of $U_B = 60\text{KB/s}$ and $D_B = 500\text{KB/s}$, respectively.

Question 1: Is it possible to transfer the file from A to all other hosts in 10 minutes or less? If so, explain how. If not, explain why not. (5')

Question 2: In order to reduce the transfer time (from A to all other hosts) you may choose one of the following improvements: (1) double A 's upload speed U_A , (2) double the other hosts' upload speed U_B , or (3) double their download speed D_B . Which one would you choose? In that case, what would be the best way to transfer the file, and how long would it take? (15')

► **Exercise 176.** A router g issues the link-state advertisement $LSA_g = \{(a, 5), (b, 1), (d, 2), (e, 5)\}$ and receives the following other advertisements, where letters (a, b, c, \dots) represent router addresses.

$LSA_a = \{(b, 3), (c, 1), (e, 4), (f, 1)\}$

$LSA_b = \{(a, 3), (c, 6), (d, 4), (g, 1)\}$

$LSA_c = \{(a, 1), (b, 6), (d, 6)\}$

$LSA_d = \{(b, 4), (c, 6), (g, 2)\}$

$LSA_e = \{(a, 4), (f, 2), (g, 5)\}$

$LSA_f = \{(a, 1), (e, 2)\}$

Based on these advertisements, write the forwarding tables of all routers. For destination addresses, use the symbolic labels a, \dots, g ; also, identify each interface by the label of the corresponding adjacent router. (20')

► **Exercise 177.** Consider the following network of autonomous systems each with the assigned prefixes. (These are the ranges of addresses held within each AS.)

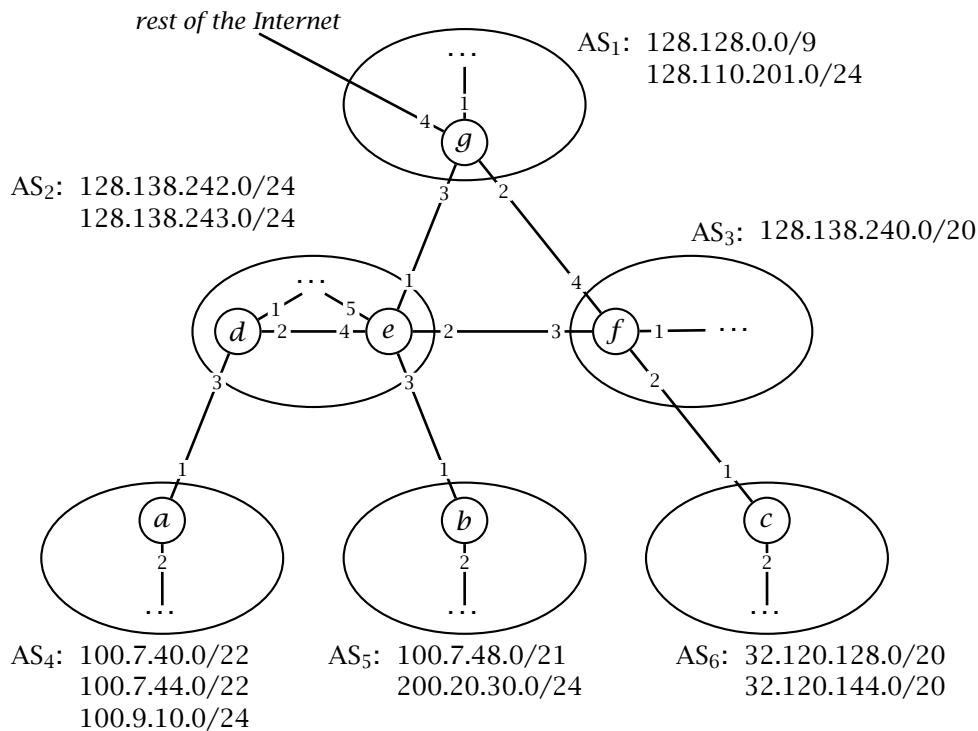

Write the forwarding tables of all the seven routers, using the actual IP prefixes and the interface numbers annotated in the figure. Routing must follow shortest paths, and addresses must be combined (“supernetting”) whenever possible. Make sure all addresses are correctly reachable, including all addresses in the rest of the network. (30’)

- **Exercise 178.** The network between hosts *A* and *B* has a maximum segment size $MSS = 1KB$, a total delay of $D = 200ms$, and an infinite transmission rate $R = \infty$. Consider the transmission of a 20KB file from *A* to *B* using TCP. Assume that *A* initiates the connection at time $t = 0$ and that the CPUs of *A* and *B* are infinitely fast such that the processing time is always zero.

Question 1: Assuming the network is perfectly reliable, write all the TCP packets exchanged by *A* and *B*. For each packet, write the time the packet is sent, the SYN and ACK flags, if present, and the sequence number and the acknowledgment number, if meaningful. For example, you should write “ $t = 123ms, A \rightarrow B, ACK, seq = 2345, ack = 3456$ ” for a packet sent at time $t = 123ms$ from *A* to *B* carrying the ACK flag, the sequence number 2345 and the acknowledgment number 3456. (15’)

Question 2: Now consider the transfer of a 200KB file, and in this case assume that the network loses the 100th packet sent by *A*. Exactly how long does it take for *A* to transmit the entire file? Justify your answer by showing a synthetic trace of the packets exchanged by *A* and *B*. In this case, do not write every single packet but instead write the initial time and the initial and final sequence number of every sequence of consecutive packets sent by *A* (e.g., “ $t = 123ms, A \rightarrow B, 10pkts, seq = 1000 \dots 11000$ ”). Show and briefly explain exactly what happens after the loss of the 100th packet. (15’)

- **Exercise 179.** A 1GB file is held by 4 “seeder” peers in a peer-to-peer file sharing group (torrent). Imagine now that 10 more peers join the group to download that file. Assume that all peers are connected to the network through an access link with maximum download and upload rates of 500KB/s and 100KB/s, respectively, and that the core of the network has infinite bandwidth.

Question 1: How long does it take for an ideal peer-to-peer protocol to complete the file transfer? Justify your answer. (10’)

Question 2: After the first file transfer is complete, how long does it take for an ideal peer-to-peer protocol to transfer the same file to 10 more peers, assuming the first 10 would also share the file? Justify your answer. (10’)

- **Exercise 180.** A robotic probe is on Mars at a time when the distance from Earth to Mars is 300 million kilometers. The radio communication between Earth and Mars is on a frequency that allows

for an error-free throughput of 1KB/s. Also, recall that the speed of light, which is the propagation speed of radio waves, is 300'000 kilometers per second.

Question 1: How long does it take to directly transmit a 1MB image from the probe to Earth? Justify your answer. (5')

Question 2: How long does it take to download five images of 1MB each using HTTP with and without pipelining? Justify your answer. (10')

Question 3: How long does it take to upload a 2Kb text file from Earth to the probe using SMTP? Assume the client is on Earth and the probe runs an SMTP server. Justify your answer. (15')

► **Exercise 181.** A university e-mail server supports a mailing list *cn@inf.usi.ch* for the computer networking class. Suppose that the mailing list includes *joe@email.ch*, *jane@gmail.com*, *mario@email.ch*, and *luigi@gmail.com*. Suppose now that *antonio@usi.ch* sends a message to the computer networking mailing list. Describe in detail all the network communications between the university server and the rest of the network. In particular, describe all SMTP sessions and all DNS messages. (20')

► **Exercise 182.** A client at address *C* downloads a 10Kb image from a server at address *S* using HTTP over a TCP connection requesting that the connection be immediately closed. Assume a maximum segment size of 1500 bytes. Write all the TCP segments exchanged between the client and the server. For each segment, write the source and destination addresses, source and destination ports, sequence number, ack number, relevant flags, and also a summary of the content. (20')

► **Exercise 183.** A company would like to distribute a 600MB file on-line. The file is downloaded many times per day by many different users. The company initially makes the file available through an HTTP server connected to the network through a network link with an upload rate of 5MB/s. All users have links with an upload rate of 100KB/s and a download rate of 3.14MB/s. Assume that the core of the network has infinite bandwidth.

Question 1: On average, how many users per hour can download the whole file? Justify your answer. (5')

Question 2: Suppose now that the company decides to support more users with a peer-to-peer protocol in which users that completed their download are encouraged to make the file available to other users. Assuming that on average a user makes their copy available for 10 minutes, ideally, how many more users per hour can download the file? Justify your answer. (15')

Question 3: Can the peer-to-peer protocol support an unlimited number of users? If so, how? (10')

► **Exercise 184.** A client host *A* opens a TCP connection with a server host *B*, sends 1MB of data as fast as possible, and then closes the connection. The path between *A* and *B* has a total (one way) delay $D = 100\text{ms}$, a maximum throughput rate $R = 100\text{KB/s}$, and a maximal segment size $MSS = 1\text{KB}$. How long does it take to complete the transmission? Assume there are no packet losses when the transmission rate is below R . Justify your answer. (20')

► **Exercise 185.** Consider the following network in which routers use distance-vector routing.

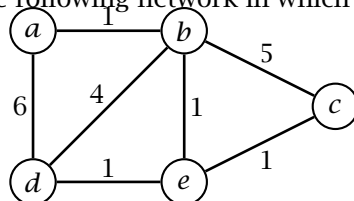

Question 1: Show the forwarding tables of routers *a* and *b* from the initialization until the state of the tables converges. Assume that all routers initialize at the same time, and that, at each round of the algorithm, each router receives distance vectors from all its neighbors simultaneously. (15')

Question 2: After convergence, the cost of the link between *b* and *e* raises from 1 to 10? Again, show the evolution of the forwarding tables of routers *a* and *b*. (15')

► **Exercise 186.** Consider using the Go-Back-N protocol over an unreliable link with transmission delay $D = 100\text{ms}$, transmission rate $R = 200\text{KB/s}$, maximum segment size $MSS = 500\text{B}$, and per-packet error probability $p = 0.01$. Define a good timeout T and a good window size W for the protocol, and based on those values, compute the expected total transmission time for a file of size $S = 600\text{MB}$. (20')

- **Exercise 187.** For each of the following ranges of IPv4 addresses, write an address prefix that defines the range exactly. If it is not possible to express the range exactly with a prefix, then write “N.E.” (meaning “not exact”) followed by a *minimal* approximate prefix, meaning a prefix that defines a minimal (smallest possible) range that contains the given range. (20’)

<i>range</i>	<i>subnet prefix-address/prefix-length</i>
34.112.126.0-34.112.127.255	
89.54.131.160-89.54.131.175	
128.138.0.0-128.138.2.255	
191.203.111.128-191.203.111.192	
241.37.144.0-241.37.151.255	
62.252.0.128-62.252.1.128	
127.0.0.0-127.255.255.255	
59.127.0.0-59.128.255.255	
0.0.0.0-255.255.255.255	
179.240.0.0-179.243.255.255	

- **Exercise 188.** A router has 10 input ports and 10 output ports. All input and output ports have the same maximum throughput of 1GB/s.

Question 1: Is it possible to design the router so that packets are never queued? If so, explain why and in particular specify the throughput of the switch fabric? If not, explain why not. (5’)

Question 2: Suppose that the switch fabric has a maximum throughput of 5GB/s, and that the input traffic is such that half of it goes to output ports 1 and 2, where it is distributed evenly, and the rest goes to the other output ports, also evenly distributed. What is the expected output of each output port? Does the router drop packets? If so, specify where and for each point specify the loss rate. If not, explain why not. (5’)

- **Exercise 189.** Consider a router with four interfaces that uses longest-prefix matching in a datagram network using 8-bit host addresses.

Question 1: Given the following forwarding table, compute how many addresses would be routed through each interface. (10’)

<i>prefix</i>	<i>port</i>
0/0	1
64/2	2
128/3	2
240/4	3
16/4	4
104/5	4
8/5	3

Question 2: Assuming now that the router connects subnets *A*, *B*, *C*, and *D*, and that *A* and *B* must each support at least 80 interfaces (i.e., addresses), and *C* and *D* must each support at least 40 interfaces. Assign the necessary addresses to each network and write the corresponding forwarding table for the router. (10’)

- **Exercise 190.** A group of 30 users download a 3GB file through a peer-to-peer system. The whole file is available from 3 other “seed” users S_1, S_2, S_3 connected to the network with access links of

maximal upload rates $U_1 = 400\text{KB/s}$ and $U_2 = 700\text{KB/s}$, and $U_3 = 1\text{MB/s}$ respectively. Of the 30 users, 10 have a fast access link and 20 have a slow access link. A fast access link has maximal upload and download rates of $U_{fast} = 200\text{KB/s}$ and $D_{fast} = 1\text{MB/s}$, respectively. A slow access link has maximal upload and download rates of $U_{slow} = 100\text{KB/s}$ and $D_{slow} = 400\text{KB/s}$, respectively. What is the theoretical best total download time? This is the time it takes for all thirty users to obtain the whole file. Justify your answer by showing and briefly explaining your calculations. (For simplicity, let 1GB and 1Kb represent 10^9 and 10^3 bytes, respectively.) (20')

- **Exercise 191.** An HTTP connection is established over a TCP connection with maximum segment size of 1400 bytes.

Question 1: Within this connection, a TCP segment with sequence number 2300 carries the following HTTP request:

```
HTTP/1.0 404 Not Found
Content-Type: text/html
Content-Length: 41
```

```
<html><body>Page Not Found!</body></html>
```

What is the sequence number of the next segment going from the Web server to the client? Justify your answer. (Remember that all HTTP header lines end with a CRLF sequence.) (10')

Question 2: Within the same connection, a TCP segment with sequence number 6500 carries the following HTTP request:

```
HTTP/1.0 200 Ok
Content-Type: image/jpg
Content-Length: 25000
```

```
a binary image...
```

What is the sequence number of the next segment sent by the server in this case? Justify your answer. (10')

- **Exercise 192.** A router has 16 input interfaces capable of receiving up to 10000 packets per second, and 16 output interfaces capable of sending 20000 packets per second.

Question 1: Let T_S be the maximum throughput of the switch fabric. What is the maximum total throughput of the router in the best case? Are there values of T_S for which the total throughput would not depend on T_S ? Justify your answers. (10')

Question 2: Consider the previous question in the case of a specific distribution of traffic. Let T_S be the maximum throughput of the switch fabric, and suppose that 20% of the input traffic goes to output interface 1, 10% to output interface 2, and the rest is distributed uniformly onto all other interfaces. What is the maximum throughput of the router in this case? Also, for what values of T_S (if any) does the router drop packets on its input and output queues, respectively? Are there any values of T_S for which neither queues would ever be full? Justify your answers. (10')

- **Exercise 193.** Consider a reliable connection between a sender and a receiver implemented with a Go-Back-N protocol with maximum segment size $MSS = 2\text{KB}$ and with a fixed window size $W = 8$. The network latency between the sender and receiver is $L = 200\text{ms}$, the access link of the sender allows a maximum transmission throughput $T_S = 100\text{KB/s}$, and both sender and receiver have very high reception throughput.

Question 1: How long does it take to reliably transmit a file of size $S = 100\text{KB}$ in the best case, without any loss of packets? Justify your answer. (10')

Question 2: Assuming the timeout is set to 1s, how long does it take to reliably transmit the same file ($S = 100\text{KB}$) in the presence of losses when one out of 20 packets gets lost in both directions? Justify your answer. (10')

- **Exercise 194.** Consider IP forwarding with longest-prefix matching.

Question 1: Briefly describe and motivate longest-prefix matching with an example network. How does it work, and why it useful? (10')

Question 2: A router in an IPv4 network using longest-prefix matching has the forwarding table shown below on the left. For each destination addresses in the table on the right, write the output port and the list all the matching table entries.

entry	destination	port
1	98.7.1.0/16	1
2	211.57.20.0/24	1
3	40.120.0.0/16	2
4	211.57.21.0/24	2
5	160.0.0.0/2	3
6	111.11.0.0/16	3
7	211.57.20.0/22	4
8	211.57.0.0/16	4
9	0.0.0.0/2	4
10	0.0.0.0/0	5

address	port	matching entries
211.57.1.69		
10.142.226.44		
98.7.2.71		
200.100.2.1		
40.120.207.167		
211.57.20.11		
211.57.21.10		

(10')

►Exercise 195. Consider the following simple network topology where routers use a distance-vector routing protocols

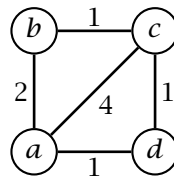

For simplicity, assume all routers start at time 0, that routing messages (i.e., distance vectors) are sent out by routers every 10 seconds, and that they are received by neighbor routers after one second. Write the first iterations of the distance-vector routing algorithm, at times 0, 10, ..., until the protocol converges to a stable state. For each iteration, list the routing tables of each router. (20')

►Exercise 196. An HTTP server issues the following replies.

```

HTTP/1.1 304 Not Modified
Date: Wed, 13 Nov 2013 10:30:00 GMT
ETag: "978140-db4-4e3bb1239a5c0"

HTTP/1.1 200 OK
Date: Wed, 13 Nov 2013 10:31:00 GMT
Last-Modified: Mon, 12 Aug 2013 07:28:31 GMT
ETag: "978140-db4-4e3bb1239a5c0"
Content-Length: 3508
Content-Type: text/html; charset=UTF-8
Connection: close
  
```

Write two plausible requests that could have generated such replies. Notice that the body of both replies is empty. (10')

►Exercise 197. Consider an HTTP client *C*, an HTTP caching proxy *P*, and an HTTP server *S* connected through a router *R* in the network depicted below, where each link is characterized by the given latency *L* and transmission rate *R* in each direction. Assume the router itself has no bandwidth limitations and introduces no delay.

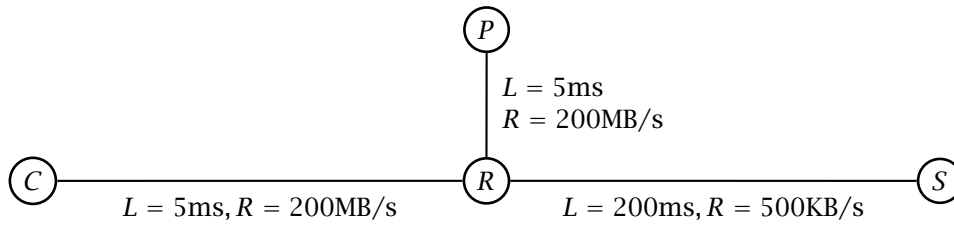

Client C accesses the Web through proxy P and issues a sequence of HTTP requests for objects whose origin server is S .

Question 1: How long does it take for client C to obtain two images $a.jpg$ and $b.jpg$ of 200KB and 100KB, respectively, assuming that neither is cached by the proxy. Justify your answer. (10')

Question 2: How long does it take for client C to obtain three images $a.jpg$, $b.jpg$, and $c.jpg$ of 200KB, 100KB, and 200KB, respectively, assuming that valid copies of $a.jpg$ and $b.jpg$ are cached by the proxy while $c.jpg$ must be fetched from the origin server. Justify your answer. (10')

- **Exercise 198.** Consider the following network between an e-mail client C , an SMTP server S_1 serving domain *usi.ch*, and another SMTP server S_2 serving and handling all the e-mail for domain *democracynow.org*.

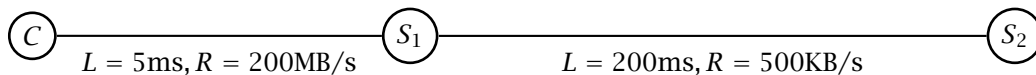

The sender using client C composes a message of 250KB (including all headers and attachments) addressed to *amy@democracynow.org* and *juan@democracynow.org*. How long would it take in the best case to deliver the message to all the intended receivers from the time the sender hits the “send” button? Justify your answer. (20')

- **Exercise 199.** Consider a sender A and a receiver B connected by a link with transmission rate $R = 1\text{MB/s}$ and latency $L = 100\text{ms}$. Sender and receiver use the *go-back- N* protocol with a segment size of 1KB and a window of W segments. Knowing that in the best case (without errors) it takes 4.02s for sender A to transfer a file of size $S = 1\text{MB}$ to B , what is the value of W used by A ? Could A improve the transfer time by choosing another window size? If so, what would be an optimal value for W and the resulting transfer time? Justify your answers. (20')

- **Exercise 200.** A file of size 300MB is published using bittorrent and immediately 10 peers join the torrent to download the file. The publisher has an upload rate of 500KB/s and the other peers contribute on average an upload rate of 350KB/s. Assume that the download rate of all the peers is high enough to be irrelevant.

Question 1: How long would it take in the best case to transfer the file to all peers? Justify your answer. (10')

Question 2: Now assume that exactly 5 minutes after the publication, another 10 peers join the torrent. These new peers share at an average upload rate of 100KB/s and have plenty of download bandwidth. In the best case, when would all the peers complete their download? Justify your answer. (20')

- **Exercise 201.** An application A transmits a continuous stream of data to another application B using a reliable transport layer on top of a link with latency $L = 40\text{ms}$, transmission rate $R = 1\text{MB/s}$, maximum segment size $S = 1\text{KB}$, and per-packet loss probability P_e .

Question 1: What is the effective transmission rate (as seen by the applications) when the transport layer uses a *stop-and-wait* protocol with a timeout $T = 100\text{ms}$? Compute the effective transmission rate for error probabilities $P_e = 1/10$, $P_e = 1/50$, $P_e = 1/100$, and $P_e = 0$, that is, if a packet is lost on average every 10, 50, 100 packets, or never. (10')

Question 2: What is the effective transmission rate when the transport layer uses a *go-back- N* protocol with a timeout $T = 100\text{ms}$ and window size $W = 100$? Again compute the effective transmission rate for error probabilities $P_e = 1/10$, $P_e = 1/50$, $P_e = 1/100$, and $P_e = 0$, that is, if a packet is lost on average every 10, 50, 100 packets, or never. (10')

- **Exercise 202.** An application A transfers a file to another application B using a TCP connection over a communication link that has a maximum throughput of 1MB/s and no additional packet losses. In other words, the link drops a packet *only* when that exceeds the maximum throughput over a certain short period. How long does it take for B to receive a 1.5GB file? Justify your answer by explaining the behavior of TCP at steady state. (**Hint:** ignore the initial and final phases of the TCP connection. Consider the overall behavior of TCP, not the individual packets.) (10')
- **Exercise 203.** A Web client connects to the Web server on host *example.com* to verify that the URL *http://example.com/image.jpg* is valid, but without transferring the object.
- Question 1:* Write the full HTTP exchange between client and server. (5')
- Question 2:* Write all the TCP packets of the connection between client and server. For each packet, specify all the important information in the IP and TCP headers (addresses, ports, flags, sequence numbers, etc.) as well as the content. (15')
- **Exercise 204.** Consider the convergence of distance-vector routing under the assumption that all routers execute the protocol in synchronous steps.
- Question 1:* Write a network of at least five nodes in which the routing protocol would converge to a stable state after exactly four steps. Also, write the routing tables at each step for one of the nodes whose tables converge last (at the fourth step). (10')
- Question 2:* After convergence, change the cost of one link so that the routing protocol would again converge to a stable state after two or more steps. Also, for each step after the change, write the routing tables of one of the nodes whose tables are affected by the change. (10')
- **Exercise 205.** Consider a router with four input and four output ports. The output ports have a maximum transmission rate of 5000 packets per second. The switch fabric has a maximum throughput of 10000 packets per second. All packet queues in the router can contain up to 1000 packets. Suppose the input traffic starts to ramp up linearly and uniformly on all input ports, from 0 packets per second at time $t = 0$ to the maximum input rate of 5000 packets per second for each input port at time $t = 10$ s. The input traffic is such that it spreads uniformly over the first three output ports, so one third of the traffic goes to ports 1-3 each, and no traffic goes to port 4.
- Question 1:* At what time and for which queues does the router start to drop packets? Would the situation change if the switch fabric were twice as fast? Justify your answers. (10')
- Question 2:* Suppose the traffic goes back to zero in the same way it ramps up, so starting at time $t = 10$ s it declines uniformly and linearly reaching zero for all input ports at time $t = 20$ s. When does the router stop dropping packets? How many packets does the router drop in total between $t = 0$ and $t = 20$ s? Justify your answers. (10')
- **Exercise 206.** A university owns the IPv4 addresses represented by prefixes 195.176.180.0/22 and 128.138.240.0/20.
- Question 1:* How many addresses does the university own in total? Justify your answer. (5')
- Question 2:* The university has one campus connected to the internet through ISP A and now opens a new campus in a different city connected through ISP B . The university assigns 320 of its IP addresses to the new campus. Write a plausible network topology that shows the two campuses and their two access ISPs, and for each ISP write the entries in the forwarding tables that are relevant to the addresses owned by the university. (15')
- **Exercise 207.** Describe the “slow start” in TCP. How does it work and what is its purpose? (10')
- **Exercise 208.** A router x issues the following link-state advertisement $LSA_x = \{(d, 1), (e, 2), (b, 4)\}$ and receives the following other advertisements, where letters represent router addresses.
- $LSA_g = \{(d, 1), (h, 1)\}$
 $LSA_h = \{(e, 2), (f, 4), (j, 14), (g, 1)\}$
 $LSA_d = \{(g, 1), (e, 3), (x, 1)\}$
 $LSA_e = \{(d, 3), (x, 2), (b, 1), (h, 2)\}$
 $LSA_f = \{(h, 4), (j, 2), (b, 2), (c, 1)\}$
 $LSA_b = \{(x, 4), (e, 1), (f, 2), (c, 4)\}$
 $LSA_c = \{(b, 4), (f, 1)\}$

Write the forwarding table of router x . Justify your answer by explaining how link-state routing works. (20')

► **Exercise 209.** A person (*bill@somewhere.net*) sends an ordinary e-mail message to *joe@coolplace.org* through a local SMTP server. Describe every network operation, at the application level, performed by your SMTP server to deliver the message. (20')

► **Exercise 210.** An application downloads 10 objects (HTML, images, and other content objects) of 50KB each using HTTP over an access link with an effective transmission rate $R = 500\text{KB/s}$. Assume that the rest of the network has unlimited bandwidth and ignore the latency introduced by DNS and the initial latency and dynamics of TCP. The transmission delay with the origin server is $L = 200\text{ms}$. Write how long it would take for the downloads to complete in each of the following cases. Justify your answers.

Question 1: The web server does not support persistent connections. (5')

Question 2: The web server supports persistent connections without pipelining. (5')

Question 3: The web server supports persistent connections with pipelining. (5')

Question 4: The web server supports persistent connection with pipelining, and the last 5 objects are in a transparent caching proxy close to the client, with a transmission delay $L = 10\text{ms}$. (5')

► **Exercise 211.** Two computers are connected through a link with transmission rate $R = 1000\text{KB/s}$ and latency $L = 100\text{ms}$.

Question 1: What is the effective throughput with a stop-and-wait transport protocol with maximum segment size $MSS = 1\text{KB}$? Briefly justify your answer. (5')

Question 2: What is the optimal window size in KB? Briefly justify your answer. (5')

Question 3: What is the effective throughput in a transmission using TCP over that link? Briefly justify your answer. (5')

Question 4: With a maximum segment size $MSS = 1\text{KB}$, how long does it take for TCP to achieve its maximum throughput? Briefly justify your answer. (5')

► **Exercise 212.** Answer the following questions regarding IP prefixes and longest-prefix matching. Briefly justify your answers.

Question 1: Is it possible to have a prefix that represents exactly 100 IP addresses? (5')

Question 2: What is the best way to represent 100 IP addresses using IP prefixes. Write a minimal set of prefixes that represents exactly 100 IP addresses. (5')

Question 3: A small network provider A owns 100 IP addresses that it sells to two customers B and C on two separate subnets. Write the forwarding tables of A 's IP router. (10')

► **Exercise 213.** Consider three applications, A , B , and C , each connected to the network through an independent access link with maximum download rate $R_d = 1000\text{KB/s}$ and maximum upload rate $R_u = 200\text{KB/s}$. What is the fastest way to send 1GB of data from A to both B and C ? Describe a transfer scheme. Detail who transfers what to whom, and when. Also, assuming no errors and perfect coordination between A , B , and C , compute the total transfer time, meaning the time it takes for both B and C to download the 1GB file? Justify your answer. (20')

► **Exercise 214.** How and why does TCP estimate the network-level round-trip time for its connection? How does TCP use the estimated round-trip time? Describe and explain the estimation algorithm using an example. Also, discuss the goal of this algorithm, showing again by example what would happen if the round-trip time is underestimated or overestimated. (20')